

# Fincor DC Drives

## Flexible & Powerful

**NEW**

Fincor single-phase DC drives provide a complete family solution – from the compact Series 2120 chassis drive to the powerful Series 2230 and it's feature rich application specific options.

Series 2230, 2330, and 2610 drives offer many features not found on competitive drives. These features promote safety and improved performance. They include:

- **Isolated Regulator** protects internal control circuits from the AC power source, operators and equipment. The control reference input common may be grounded or connected without additional isolation to additional drives or grounded external sources. Isolation eliminates the common condition of line voltage to ground potential being present at the operator station potentiometer.

- **External DC Signal Follower** includes isolation and impedance matching circuitry to interface an externally supplied grounded or ungrounded, isolated or non isolated 0-5 VDC, 0-10 VDC or 4-20 mA DC signal source, with the motor controller reference input. This provides a linear transfer of the external signal to motor speed.

- **AC Line Starting (Auto-Restart)** selection simplifies restart control wiring requirements. This selection also permits run-stop control of unidirectional models by using an external AC line contactor. Smooth starting capabilities are included.

- **DC Tachometer Feedback** provides wider speed range, improved speed regulation with load changes and reduced sensitivity to operating conditions such as line voltage variations, ambient temperature changes, motor field heating and other operating variables. The controller will automatically transfer to counter EMF voltage feedback to prevent run away if the tachometer circuit is disconnected. Tachometers producing 7 to 150 VDC at maximum motor speed may be used.



### TYPICAL APPLICATIONS

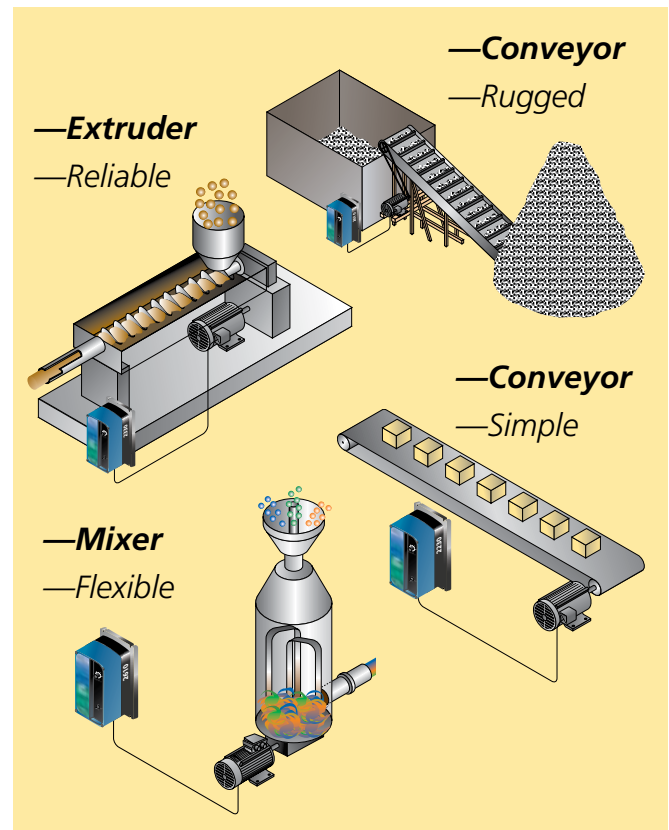

Contact factory for "Operator Stations"

- Analog DC Drive
- 1/8 to 5 hp (115-230 VAC)
- Non-Regen and Regen Models
- Chassis, Bookshelf or NEMA 4/12
- Tachometer or Armature Feedback
- Complete Motor Solutions



### CHOOSE NON-REGEN OR REGENERATIVE

Non-regenerative drives are used when friction or a dynamic brake stopping is adequate. A contactor may be used to achieve reversing operation. Non-regen drives are less expensive than Regen drives when reversing is not required.

Regenerative drives include static reversing and are used when you need four quadrant control or Forward & Reverse operation from a bidirectional control signal (+/- 10 VDC). It will stop the load smoothly and faster than a dynamic brake for fast stop or emergency stop requirements and it will regenerate power to the supply if the load is overhauling (wanting to go faster than the motor set speed).

### CHOOSE DRIVE SERIES

Now choose the drive series from either Non-Regen or Regen product pages. The chart below compares features and horsepower ratings, with the simplest and least expensive drive at the top and highest horsepower range and flexibility towards the bottom.

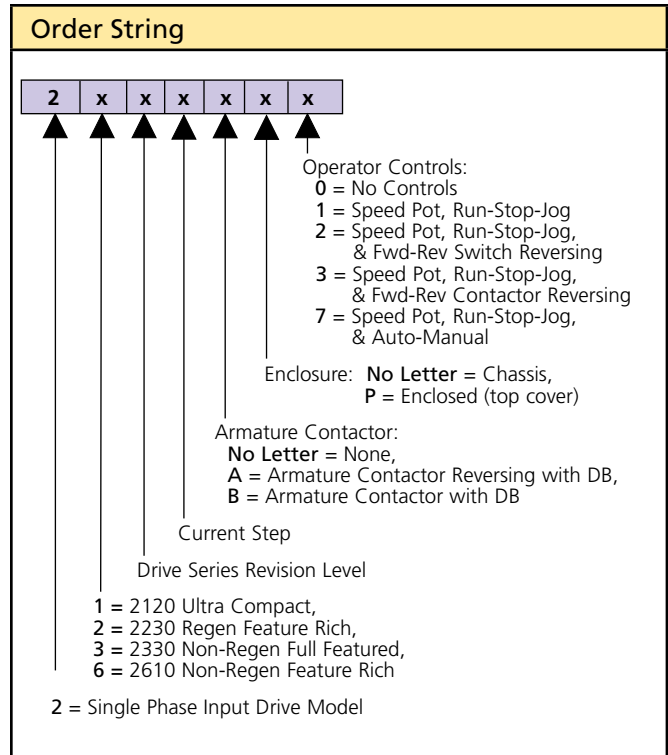

### Fincor Single Phase DC Selection Chart

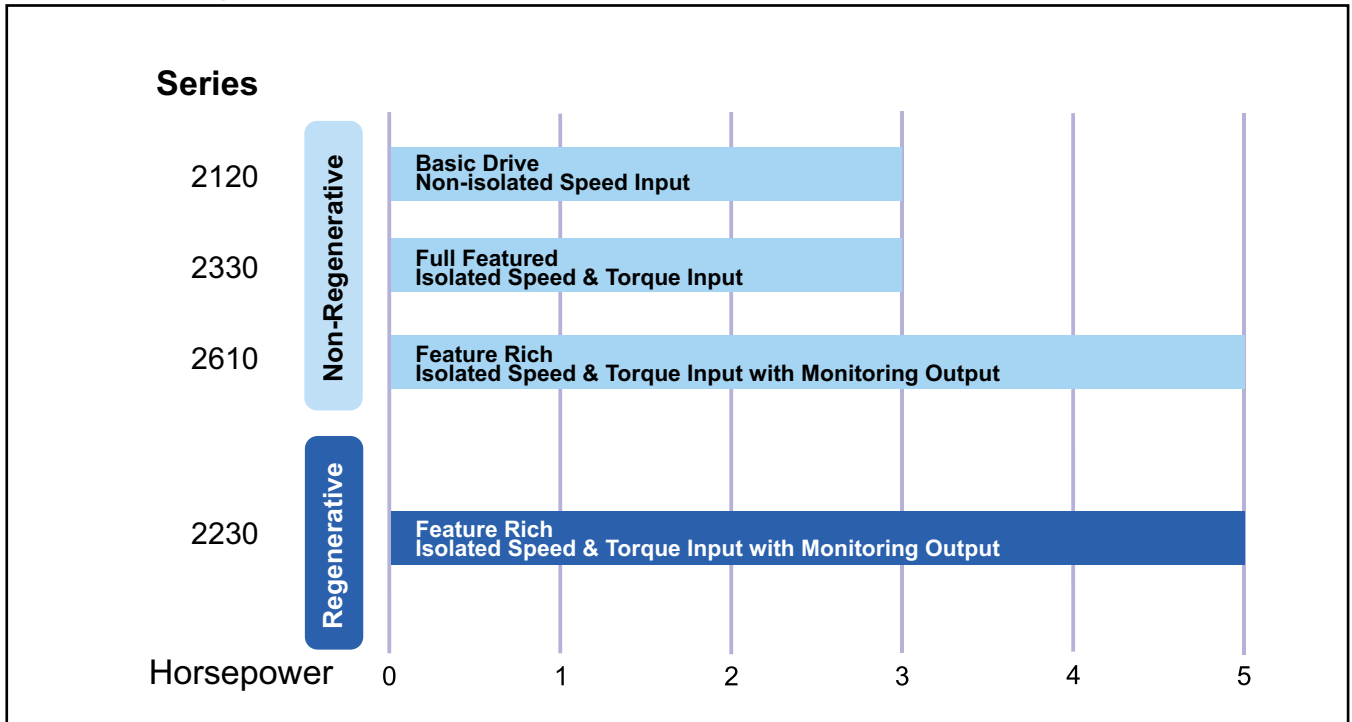

Contact your local Distributor, Control Techniques' Representative or see www.emersonct.com for upgrade and cross reference information regarding Focus, Puma or Lynx series DC drives.

Fincor

# Fincor Non-Regen Drives

Non-regenerative drives are typically used on applications which primarily motor in one direction and stopping is achieved through friction or infrequent use of a dynamic braking resistor. These drives may provide speed or torque control from a potentiometer or unidirectional (0-10 VDC or 4-20 mA) control signal. Reversing requires a switch or

contact closure to initiate the change. Upon the reversing signal, the drive will allow the motor to coast to a stop (or perform a control stop under a decel ramp with control stop option) or utilize a dynamic braking resistor to pull it to a stop before switching the motor leads with a contactor and starting the motor in the opposite direction.

## Fincor Series 2120

Fincor Series 2100 drives feature compact size and lowest pricing. Chassis units are dimensionally interchangeable with many competitive units and are ideal for the OEM or panel builder who builds a custom system by integrating the drive into an enclosure with special logic or auxiliary control devices. NEMA 1 enclosed units are complete self-contained packages ready for wall or machine mounting.

- 1/8 to 3 hp (115 -230V)
- Budget Priced
- Speed Control
- Current Limit
- UL Listed



### RATINGS: 1/8 TO 3 hp (115-230 VAC)

Series 2100 Non-Regenerative DC Drives								
Model	Motor HP <sup>2</sup>	Input		Output				RUN-STOP
		AC Volts	Amps	DC Volts		Amps		Order Code
				Arm	Field	Arm	Field	
Chassis <sup>1</sup>	1/8-1/2	115	8.7	90	50/100	5.4	1.0	2121
	1/8-1/2	115	8.7	90	50/100	5.4	1.0	2122
	1/2-1.0	230	8.8	180	100/200	5.5	1.0	2122H
	1/8-1.0	115	15	90	50/100	10.5	1.0	
	1/2-2.0	230	15.8	180	100/200	11.6	1.0	2123
	1/8-1.0	115	15	90	50/100	10.5	1.0	
NEMA 1 Enclosed	1/8-1/2	115	8.7	90	50/100	5.4	1.0	2121P1
	1/2-1.0	230	8.7	180	100/200	5.4	1.0	2122P1

(2) Units may be easily recalibrated using trim pots for any standard rating within the hp range.

Option Description	Order Code
Knob and Dial Plate Kit — This option provides a knob and a dial face graduated 0-100% for use with the potentiometer provided with Series 2120 chassis drives.	2067109
External Signal Follower/Isolation — For use with isolated or non isolated 4-20 mA DC, 0-10 VDC signals. Includes a scaling potentiometer for offset adjustment. Dimensions 1.5" (38) X 3.38" (86) X .75" (19).	106409401

# Fincor Series 2120

## SPECIFICATIONS:

### Operating Conditions

Horsepower	1/8 thru 3 hp , Trim Pot Selectable
Line Voltage	115-230 VAC ±10%, Bi Voltage Input*
Rated Frequency	50/60 Hz ±2%
Enclosure	Chassis, NEMA 1
Ambient Temperature	0 – 40°C (32°F - 104°F) (Enclosed)
	0 – 55°C (32°F - 131°F) (Chassis)
Altitude	1000 m (3,300 ft)
Relative Humidity	95% Non condensing
Overload Capacity	150% for 1 minute

### Standard Features

Regulator Function	Speed Regulated
Power Conversion	2 SCR plus Freewheeling Diode
Field Supply	Full Wave
Protection	MOV Voltage Transient Suppression High Interrupting Capacity Line Fuse
Speed Regulation	Armature or DC Tach Feedback*

### Control

Control Logic Power	Common for Maintained Switch
Speed Potentiometer	5K Ohms, ½ Watt
Input Reference	0 – 10 VDC
Speed Regulation	2% with Armature Feedback 1% with Tachometer Feedback*

### Adjustments

Maximum Speed	60% – 100% of Motor Base Speed
Minimum Speed	0% – 40% of Motor Base Speed
Current Limit	0 – 150% of Full Load
IR Compensation	0 – 100% Boost
Acceleration/Deceleration	0-4 Seconds*

### Efficiency

Controller (only)	98%
With Motor (typical)	85%

### Approvals & Listings

UL and cUL

\* The 2121, 2121P1 and 2122P1 are single input voltage (115, 115 & 230 VAC respectively), do not offer DC Tach Feedback, and have fixed acceleration and deceleration rates.

## DIMENSIONS

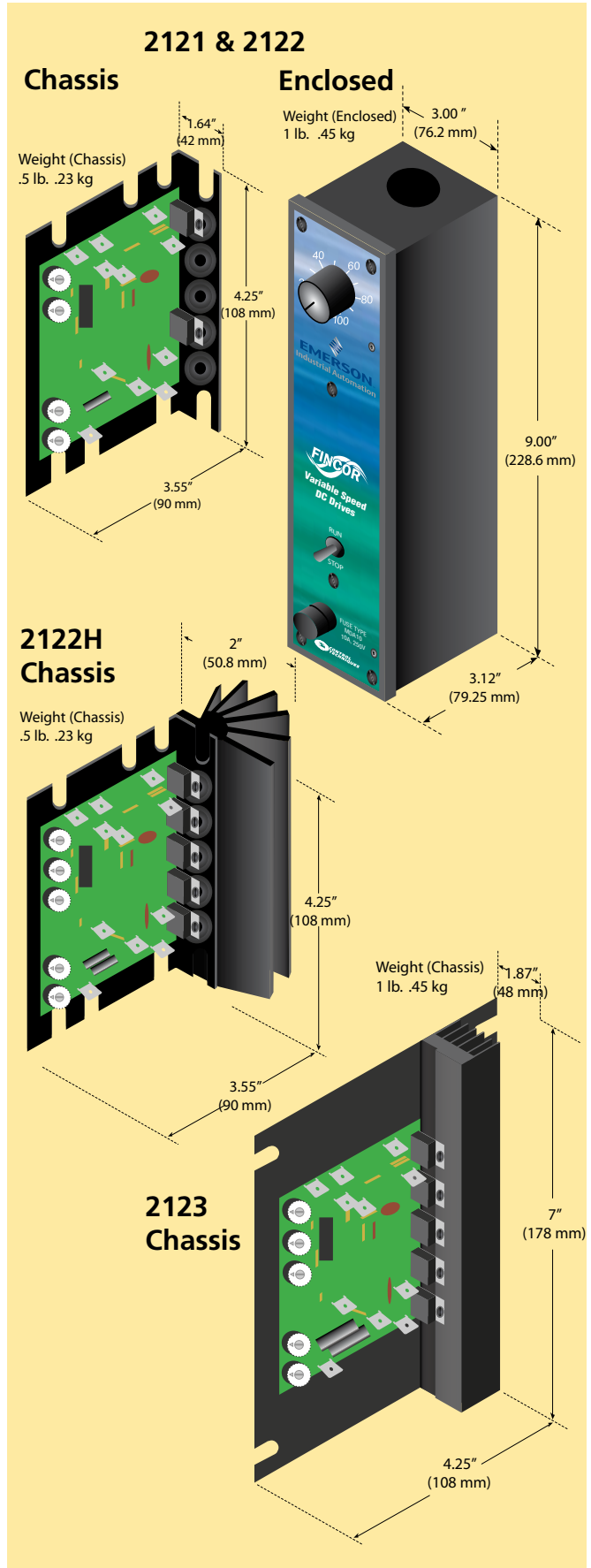

# Fincor Series 2330

Fincor Series 2330 drives features a fully isolated regulator using surface mount technology. It includes an isolated customer run contact, low voltage operator control circuitry, and full wave power conversion.



Bookcase



Enclosed

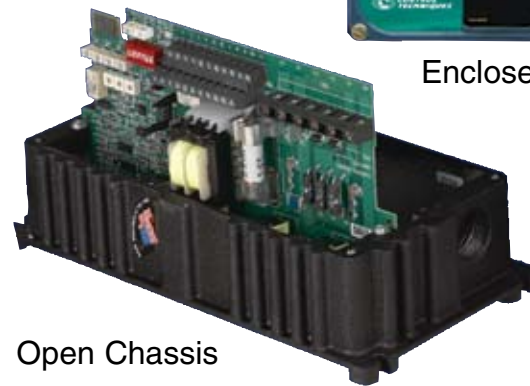

Open Chassis

- 1/8 to 5 hp (115-230V)
- Fully Isolated Regulator
- Speed or Torque Control
- 0-10 VDC or 4-20 mA Input Signal
- Fused Input
- Line Start (Auto Restart)
- Dual Field Supply
- Tachometer Input standard

## RATINGS: 1/8 TO 5 hp (115-230 VAC)

Series 2330 Non-Regenerative DC Drives										
Model	Motor HP	Input		Output				Run-Stop, (Basic)	Run-Stop, Arm. Cont. DB	Run-Stop, Arm. Cont., Rev. & DB
		AC Volts	Amps	DC Volts		Amps		Order Code	Order Code	Order Code
				Arm	Field	Arm	Field			
Chassis w/o Operator Controls	1/8-1.0	115	15.8	90	50/100	10.5	1.0	2331	2331B	2331A
	1/2-2.0	230	15.8	180	100/200	11.6	1.0			
	1/8-1.0	115	15.8	90	50/100	10.5	1.0	2332	2332B	2332A
	1/2-3.0	230	22	180	100/200	15.1	1.0			
Bookcase w/o Operator Controls	1/8-1.0	115	15.8	90	50/100	10.5	1.0	2335	2235B	2235A
	1/2-2.0	230	15.8	180	100/200	11.6	1.0			
	1/8-1.0	115	15.8	90	50/100	10.5	1.0	2336	2336B	2336A
	1/2-3.0	230	22	180	100/200	15.1	1.0			
NEMA 4/12 w/o Operator Controls	1/8-1.0	115	15.8	90	50/100	10.5	1.0	2331P0	2331BP0	2331AP0
	1/2-2.0	230	15.8	180	100/200	11.6	1.0			
NEMA 4/12 with Integral Operator Controls	1/8-1.0	115	15.8	90	50/100	10.5	1.0	2331P1*	2331BP1*	2331AP3
	1/2-2.0	230	15.8	180	100/200	11.6	1.0			
	1/8-1.0	115	15.8	90	50/100	10.5	1.0			2331P2*
	1/2-2.0	230	15.8	180	100/200	11.6	1.0			

Units shipped calibrated for desired hp rating but jumpers can be adjusted for others. Units shipped ready for 230VAC but may be reconnected for 115VAC.

\* P1, BP1, & P2 have additional Jog controls. 2331P2 includes switch reversing (not contactor) without DB.

# Fincor Series 2330

## SPECIFICATIONS:

### Operating Conditions

Horsepower	1/8 thru 3 hp, Jumper Selectable
Line Voltage	115-230 VAC ±10%, Jumper Selectable
Rated Frequency	50/60 Hz ±2%
Enclosure	Chassis, Bookcase, NEMA 4/12
Ambient Temperature	0 – 40°C (32°F - 104°F) ( <i>Enclosed</i> ) 0 – 55°C (32°F - 131°F) ( <i>Chassis</i> )
Altitude	1000 m (3,300 ft)
Relative Humidity	95% Non condensing
Overload Capacity	150% for 1 minute (UL Listed Motor Overload Protection) (120% Timing Threshold)

### Standard Features

Isolated Regulator Circuit	Grounded I/O signals possible
Regulator Function	Speed or Torque selectable
Power Conversion	4 SCR plus Freewheeling Diode
Field Supply Protection	Full or Half Wave MOV Voltage Transient Suppression High Interrupting Capacity Line Fuse
Speed Regulation	Armature or DC Tach Feedback
Line Start	Selectable for Auto Restart
Diagnostic LED	Green Normal – Red Current Limit
Option Connector	Connects Additional Option Boards

### Control

Control Logic Power	24 VDC for Maintained Switch or Push button Operation
Speed Potentiometer	5 KOhms, ½ Watt
Input Reference	0 – 10 VDC or 4 – 20 mA
Speed Regulation (95% Load Change)	2% with Armature Feedback 0.5% with Tachometer Feedback

### Adjustments

Maximum Speed	50% – 100% of Motor Base Speed
Minimum Speed	0% – 40% of Motor Base Speed
Current Limit	0 – 150% of Full Load
IR Compensation	0 – 100% Boost
Acceleration/Deceleration	0.2 – 30 Seconds

### Efficiency

Controller (only)	98%
With Motor (typical)	85%

### Approvals & Listings

UL and cUL

## DIMENSIONS

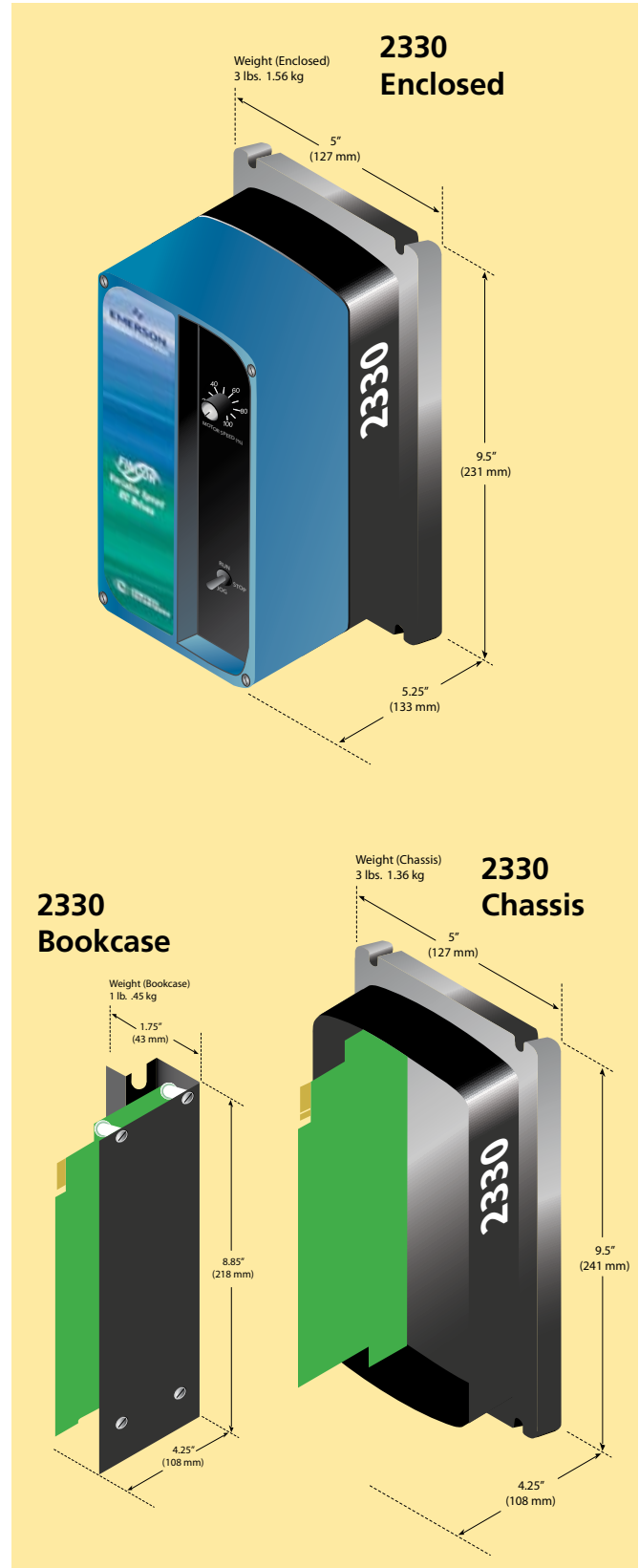

Fincor

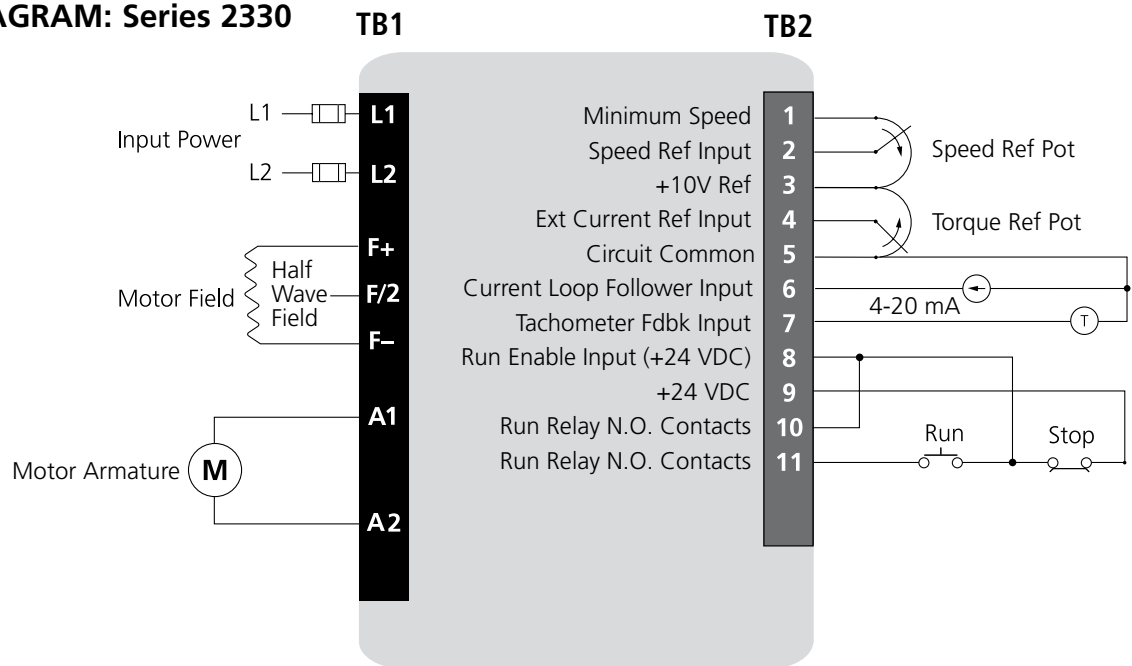
**TERMINAL DIAGRAM: Series 2330**

FinCor

**TERMINAL DESCRIPTION**
**TB1**

Pin#	Type	Notes
L1	Line Voltage Input	115 or 230 VAC J1 Selectable
L2	Line Voltage Input	115 or 230 VAC J1 Selectable
F+	Field Voltage Output	+100 VDC @ 115 VAC or +200 VDC @230 VAC Input
F/2	Field Voltage (Half-Wave) Output	+50 VDC @ 115 VAC or +100 VDC @230 VAC Input
F-	Field Voltage Output	Field Minus Output
A1	Armature + Output	0 to +90 VDC @ 115 VAC or 0 to +180 VDC @ 230 VAC Input
A2	Armature - Output	Armature Minus Output

**TB2**

Pin#	Type	Notes
1	Speed Reference Pot '0' End	With On-board Min Speed Pot Active
2	Speed Reference Input	200 K $\Omega$ Input Resistance
3	+10V Reference Output	5mA max
4	External Current Reference Input FWD	Refer to DIP Switch SW3-
5	Circuit Common	Isolated From Line – Can be connected to Earth
6	Current Loop Follower Input	Refer to DIP Switch SW3-2 (1 – 5 mA, 4 – 20 mA, 5 – 50 mA)
7	Tachometer Input (Speed Feedback)	Polarity Insensitive for Reversing Applications (3-30 Vdc, 31-175 VDC)
8	Enable Input (+24 VDC) – Run Relay	24 VDC @ 6ma Input
9	+24 VDC	For drive enable use only
10	Run Relay N.O. Contacts	Form A Contact Rated 0.5 A @ 115 VAC or 2 A @ 30 VDC
11	Run Relay N.O. Contacts	

# Fincor Series 2610

Fincor Series 2610 drives feature a fully isolated regulator using surface mount technology. It includes additional inputs and outputs with advanced control capabilities.

- 1/8 to 5 hp (115 – 230 VAC)
- Fully Isolated Regulator
- Speed or Torque Control
- 0 – 10 VDC or 4 – 20 mA input signal
- PID / Speed Trim Control
- Monitoring Output (0 – 10 VDC or 4 – 20 mA)
- Line Start /Auto Restart Enable/Disable
- Dual Field Supply
- DC-Tachometer Input

2610 Enclosed



Open Chassis

**RATINGS: 1/8 TO 5 hp (115-230 VAC)**

Series 2610 Non-Regenerative DC Drives										
Model	Motor HP	Input		Output				Run-Stop, (Basic)	Run-Stop, Arm. Cont. DB	Run-Stop, Arm. Cont., Rev. & DB
		AC Volts	Amps	DC Volts		Amps		Order Code	Order Code	Order Code
				Arm	Field	Arm	Field			
Chassis	1/8-1.0	115	15.8	90	50/100	10.5	1.0	2611	2611B	2611A
	1/2-2.0	230	15.8	180	100/200	11.6	1.0			
	1/8-1.0	115	15.8	90	50/100	10.5	1.0	2612	2612B	2612A
	1/2-3.0	230	22	180	100/200	15.1	1.5			
	1/8-1.0	115	15.8	90	50/100	10.5	1.0			
Bookcase w/o Operator Controls	1/2-5.0	230	32	180	100/200	25	2.0	2613	2613B	2613A
	1/8-1.0	115	15.8	90	50/100	10.5	1.0	2615	2615B	2615A
NEMA 4/12 w/o Integral Operator Controls	1/2-2.0	230	15.8	180	100/200	11.6	1.0			
	1/8-1.0	115	15.8	90	50/100	10.5	1.0			
	1/2-5.0	230	32	180	100/200	25	2.0	2613P0	2613BP0	2613AP0
	1/8-1.0	115	15.8	90	50/100	10.5	1.0			
NEMA 4/12 with Integral Operator Controls	1/8-1.0	115	15.8	90	50/100	10.5	1.0	2611P1*	2611BP1*	2611AP3*
	1/2-2.0	230	15.8	180	100/200	10.5	1.0			
	1/8-1.0	115	15.8	90	50/100	10.5	1.0	2613P1*	2613BP1	2613AP3*
	1/2-5.0	230	32	180	100/200	25	2.0			
	1/8-1.0	115	15.8	90	50/100	10.5	1.0	2611P7	2611BP7	Manual / Auto Switch.
	1/2-2.0	230	15.8	180	100/200	11.6	1.0			
	1/8-1.0	115	15.8	90	50/100	10.5	1.0			
	1/2-2.0	230	22	180	100/200	15.1	1.5			
	1/8-1.0	115	15.8	90	50/100	10.5	1.0	2613P7	2613BP7	
	1/2-5.0	230	32	180	100/200	25	2.0			

Units shipped calibrated for desired hp rating but jumpers can be adjusted for others. Units shipped ready for 230 VAC but may be reconnected for 115 VAC.

\* P1, PB1, AP3, P2 have additional Jog controls. 2611P2 includes switch reversing (not contactor) without DB.

# Fincor Series 2610

## SPECIFICATIONS:

### Operating Conditions

Horsepower	1/8 thru 5 hp, Jumper Selectable
Line Voltage	115-230 VAC ±10%, Jumper Selectable
Rated Frequency	50/60 Hz ±2%
Enclosure	Chassis, Bookcase, NEMA 4/12
Ambient Temperature	0 – 40°C (32°F - 104°F) ( <i>Enclosed</i> ) 0 – 55°C (32°F - 131°F) ( <i>Chassis</i> )
Altitude	1000 m (3,300 ft)
Relative Humidity	95% Non condensing
Overload Capacity	150% for 1 minute (UL Listed Motor Overload Protection – File # E184521) (120% Timing Threshold)

### Standard Features

Isolated Regulator Function	Grounded I/O signals possible
Regulator Function	Speed or Torque selectable
Power Conversion	4 SCR plus Freewheeling Diode
Field Supply Protection	Full or Half Wave MOV Voltage Transient Suppression High Interrupting Capacity Line Fuse
Speed Regulation	Armature or DC Tach Feedback
Line Start	Selectable for Auto-Restart
Controlled Stop	Provides ramp to stop function
Zero Speed Indication	Open Collector – Active Low
Speed Regulation Node	External PID Input or Speed Trim
Speed Outputs	0 – 10 VDC and 4 – 20 mA
Torque Outputs	0 – 10 VDC and 4 – 20 mA
Diagnostic LED	Green Normal – Red Current Limit
Option Connector	Connects Additional Option Boards

### Control

Control Logic Power	24 VDC for Maintained Switch or Push button Operation
Speed Potentiometer	5 kOhms, ½ Watt
Input Reference	0 – 10 VDC or -10 – +10 VDC
Speed Regulation (95% Load Change)	2% with Armature Feedback 0.5% with Tachometer Feedback

### Adjustments

Maximum Speed	50% – 100% of Motor Base Speed
Minimum Speed	50% – 40% of Motor Base Speed
Current Torque Limit	0% – 150% of Full Load
IR Compensation	0 – 10% Boost
Acceleration/Deceleration	0.1 – 30 Seconds
Voltage (Speed) Stability	Speed Gain Fine Tune
Current (Torque) Stability	Current Gain Fine Tune

### Efficiency

Controller (only)	98%
With Motor (typical)	85%

### Approvals & Listings

UL and cUL

## DIMENSIONS

2613Px Enclosed and 2613 Chassis see page 293

2610 Enclosed

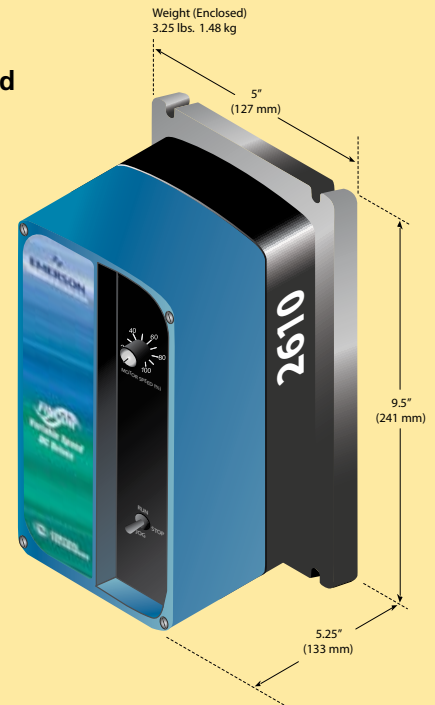

Weight (Bookcase) 1 lb. .45 kg

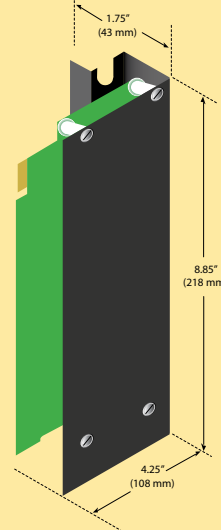

2615 Bookcase

Weight (Chassis) 3 lbs. 1.36 kg

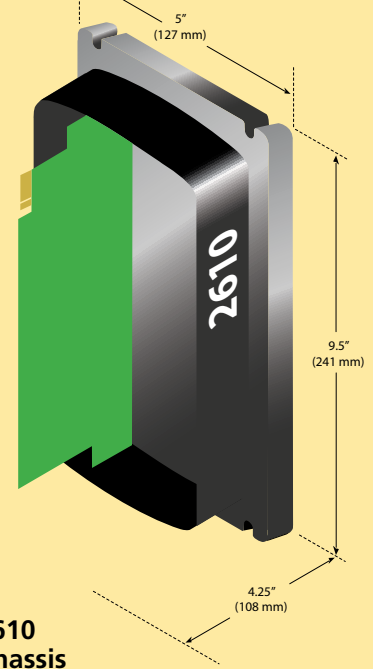

2610 Chassis

# Fincor Series 2613 & 2233 5 hp drive dimensions

**NEW**

The new 5 hp rating in the 2613 non-regenerative series and the 2233 regenerative series combine industry leading Fincor electronics with the Control Techniques Focus series enclosure to achieve more customer value.

Standard features include a fully isolated circuit board using surface mount technology, speed or torque control, PID/Speed Trim control, Monitoring Output, and DC Tachometer Input.



Please see the respective 2610 series and 2230 series sections for specifications and more details regarding these drives..

## DIMENSIONS

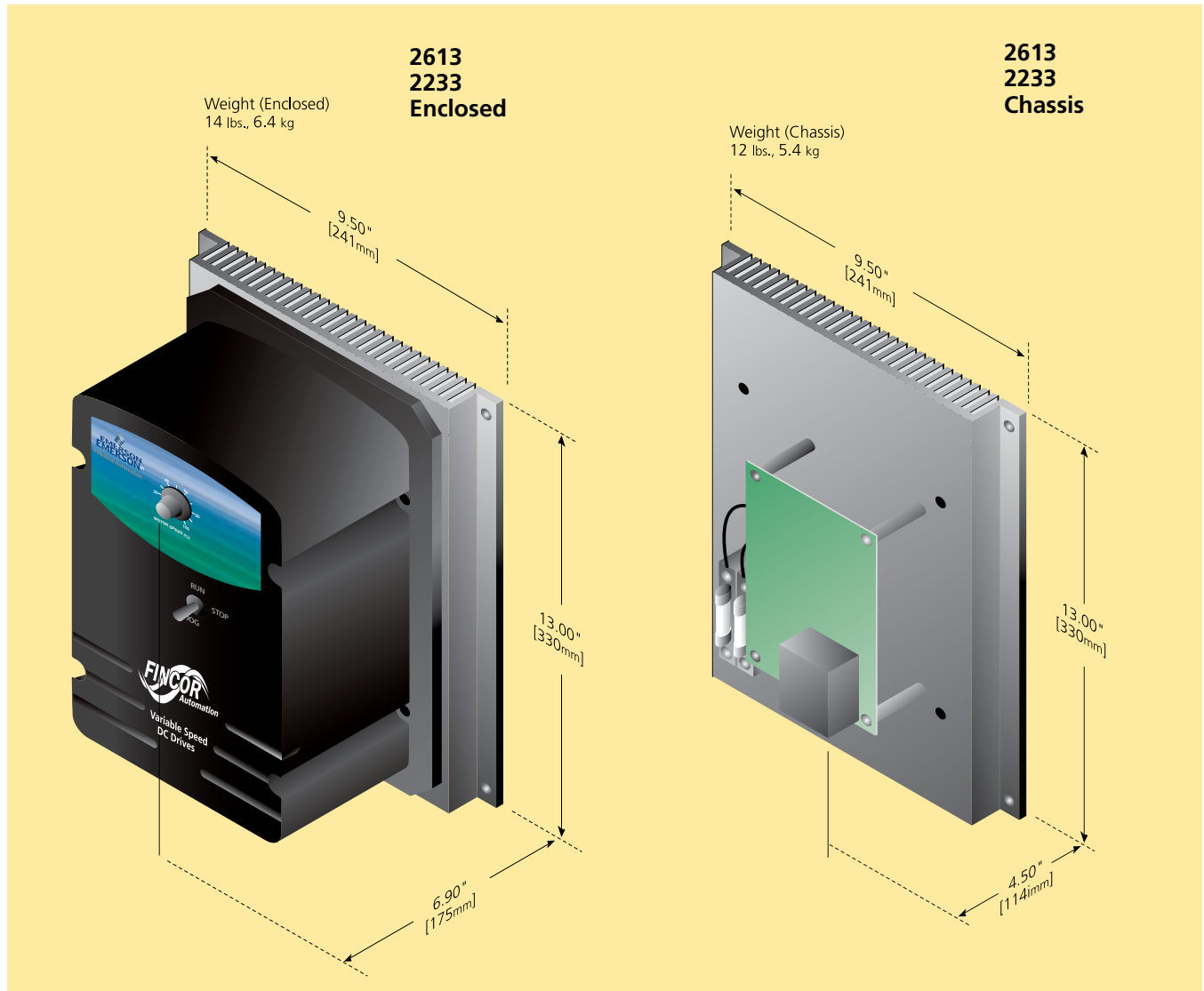

Fincor

### TERMINAL DIAGRAM: Series 2610

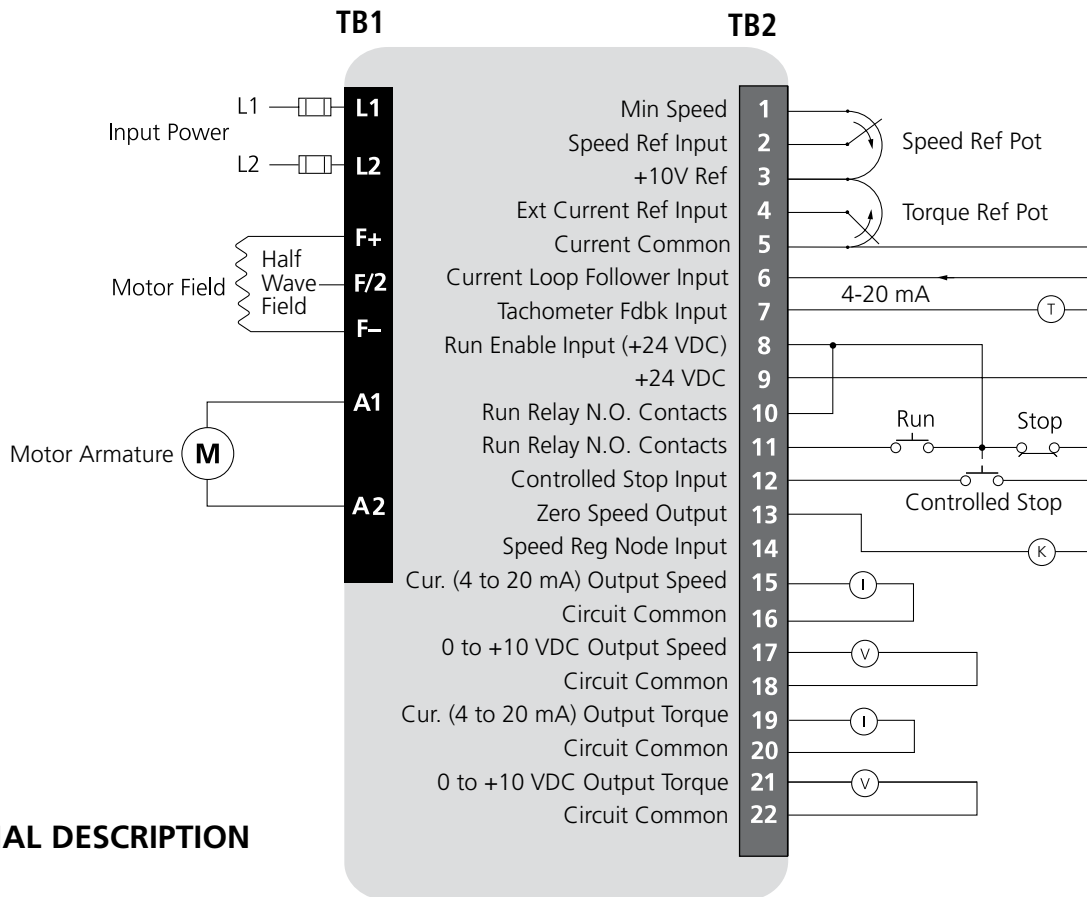

### TERMINAL DESCRIPTION

#### TB1

Pin#	Type	Notes
L1	Line Voltage Input	115 or 230 VAC J1 Selectable
L2	Line Voltage Input	115 or 230 VAC J1 Selectable
F+	Field Voltage Output	+100 VDC @ 115 VAC or +200 VDC @230 VAC Input
F/2	Field Voltage (Half-Wave) Output	+50 VDC @ 115 VAC or +100 VDC @230 VAC Input
F-	Field Voltage Output	Field Minus Output
A1	Armature + Output	0 to +90 VDC @ 115 VAC or 0 to +180 VDC @ 230 VAC Input
A2	Armature - Output	Armature Minus Output

#### TB2

Pin#	Type	Notes
1	Speed Reference Pot '0' End	With On-board Min Speed Pot Active
2	Speed Reference Input	200 KΩ Input Resistance
3	+10V Reference Output	5ma max
4	External Current Reference Input	Refer to DIP Switch SW3-2 (1 – 5 mA, 4 – 20 mA, 5 – 50 mA)
5	Circuit Common	Isolated From Line – Can be connected to Earth
6	Current Loop Follower Input	Refer to DIP Switch SW3-2 (1 – 5 mA, 4 – 20 mA, 5 – 50 mA)
7	Tachometer Input (Speed Feedback)	Polarity Insensitive for Reversing Applications (3-30 VDC, 31-175 VDC)

#### TB2 Continued

Pin#	Type	Notes
8	Enable Input (+24 VDC) – Run Relay	24 VDC @ 6 mA Input
9	+24 VDC	For drive enable use only
10	Run Relay N.O. Contacts	Form A Contact Rated 0.5A @ 115 VAC or 2A @ 30 VDC
11	Run Relay N.O. Contacts	
12	Controlled Stop Input (+24 VDC)	Momentary +24 VDC Input to Initiate Controlled (Ramp) to Stop
13	Zero Speed Indication Output	Open Collector, Active Low, Rated 24 VDC @ 50 mA
14	Speed Regulator Node Input	Speed Trim or External PID Input (Bypasses Accel/Decel Ramps)
15	Current Loop Output	4 to 20 mA – Speed (Arm Volts)
16	Current Loop Output	4 to 20 mA – Speed (Arm Volts)
17	Voltage Output	0 to 10 VDC – Speed (Arm Volts)
18	Voltage Output Common	Isolated From Line – Can be connected to Earth
19	Current Loop	Output 4 to 20 mA – Torque (Arm Amps)
20	Current Loop	
21	Voltage Output	0 to 10 VDC – Load (Arm Amps)
22	Voltage Output Common	Isolated From Line – Can be connected to Earth

# Fincor Regenerative DC Drives

Regenerative adjustable speed drives also known as four-quadrant drives, are capable of controlling not only the speed and direction of motor rotation, but also the direction of motor torque. This is illustrated below.

The term regenerative describes the ability of the drive under braking conditions to convert the mechanical energy of the motor and connected load into electrical energy which is returned (or regenerated) to the AC power source.

When the drive is operating in Quadrants I & III, both motor rotation and torque are in the same direction and it functions as a conventional non-regenerative drive. The unique characteristics of a regenerative drive are apparent in Quadrants II & IV. In these quadrants, the motor torque opposes the direction of motor rotation which provides a controlled braking or retarding force. A high performance regenerative drive, such as the Series 2230, is able to switch rapidly from motoring to braking modes while simultaneously controlling the direction of motor rotation.

## TYPICAL APPLICATIONS

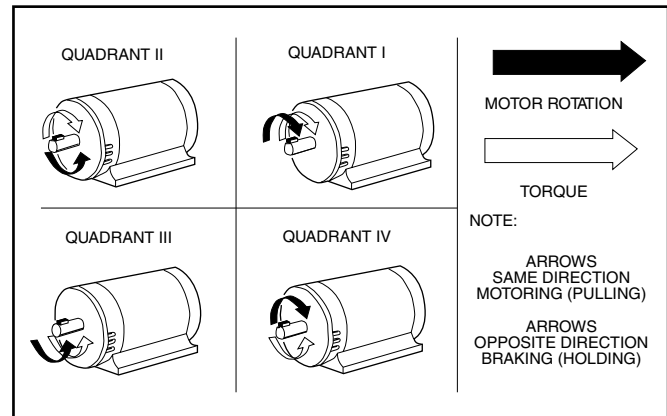
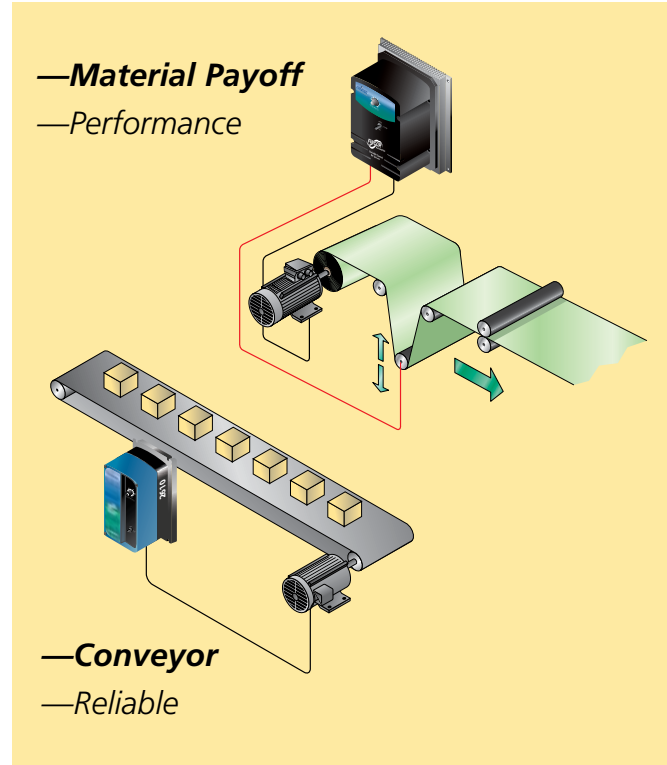

Regenerative drives provide reversing without the use of a contactor. This reduces system cost while eliminating moving parts and greatly improving reversing and braking performance.

Although the regenerative drive eliminates the requirement of a contactor for reversing or normal operational braking, a contactor is used if dynamic braking is still required. Although regenerative braking stops the motor and its load faster under normal conditions, a dynamic brake may be required to stop the motor and its connected load in emergency stop conditions such as drive failure or if the drive enable is removed before the motor comes to a complete stop.

# Fincor Series 2230

Fincor Series 2230 regenerative drives are ideal for your more demanding application with ratings up to 5 horsepower. Regenerative drives handle reversing without contactors and are able to stop faster. They feature a fully isolated regulator using surface mount technology.

- 1/8 to 5 hp (115-230V)
- Fully Isolated Regulator
- Speed or Torque Control
- 0-10 VDC or +/- 10 VDC Input Signal
- PID / Speed Trim Control
- Current Stability Adjust
- Speed or Current Monitoring (0-10 VDC or 4-20 mA)
- Fused Input
- Line Start / Auto Restart Enable / Disable
- Dual Field Supply
- DC Tachometer Input
- Diagnostic LED

2230 Enclosed



Open Chassis

Bookcase

## RATINGS: 1/8 TO 5 hp (115-230 VAC)

Series 2230 Regenerative DC Drives									
Model	Motor HP	Input		Output				Run-Stop- Jog *	Run-Stop-Jog, DB **
		AC Volts	Amps	DC Volts		Amps		Order Code	Order Code
				Arm	Field	Arm	Field		
Chassis w/o Integral Operator Controls	1/8 - 1.0	115	15.8	90	50/100	10.5	1.0	2231	2231B
	1/2 - 2.0	230	15.8	180	100/200	11.6	1.0		
	1/8 - 1.0	115	15.8	90	50/100	10.5	1.0	2232	2232B
	1/2 - 3.0	230	22	180	100/200	15.1	1.0		
	1/8 - 1.0	115	15.8	90	50/100	10.5	1.0	2233	2233B
	1/2 - 5.0	230	32	180	100/200	25	2.0		
Book Case w/o Integral Operator Controls	1/8 - 1.0	115	15.8	90	50/100	10.5	1.0	2235	2235B
	1/2 - 2.0	230	15.8	180	100/200	11.6	1.0		
	1/8 - 1.0	115	15.8	90	50/100	10.5	1.0	2236	2236B
	1/2 - 3.0	230	22	180	100/200	15.1	1.0		
NEMA 4/12 w/o Operator Controls	1/8 - 1.0	115	15.8	90	50/100	10.5	1.0	2231P0	2231BP0
	1/2 - 2.0	230	15.8	180	100/200	11.6	1.0		
	1/8 - 1.0	115	15.8	90	50/100	10.5	1.0	2233P0	2233BP0
	1/2 - 5.0	230	32	180	100/200	25	2.0		
NEMA 4/12 with Integral Operator Controls	1/8 - 1.0	115	15.8	90	50/100	10.5	1.0	2231P1	2231BP1
	1/2 - 2.0	230	15.8	180	100/200	11.6	1.0		
	1/8 - 1.0	115	15.8	90	50/100	10.5	1.0	2233P1	2233BP1
	1/2 - 5.0	230	32	180	100/200	25	2.0		

Units shipped calibrated for desired hp rating but jumpers can be adjusted for others. Units shipped ready for 230 VAC but may be reconnected for 115 VAC.

\* Run-Stop-Jog with Static (Contactor-less) Reversing using -100 to 100% Speed Potentiometer

\*\* Run-Stop-Jog with Armature Contactor and Dynamic Braking. Reversing uses -100 to 100% Speed Potentiometer

# Fincor Series 2230

## SPECIFICATIONS:

### Operating Conditions

Horsepower	1/8 thru 5 hp, Jumper Selectable
Line Voltage	115-230 VAC ±10%, Jumper Selectable
Enclosure	Chassis, Bookcase, NEMA 4/12
Rated Frequency	50/60 Hz ±2% Selectable
Ambient Temperature	0 – 40°C (32°F - 104°F) (Enclosed) 0 – 55°C (32°F - 131°F) (Chassis)
Altitude	1000 m (3,300 ft)
Relative Humidity	95% Non condensing
Overload Capacity	150% for 1 minute (UL Listed Motor Overload Protection – File # E184521) (120% Timing Threshold)

### Standard Features

Isolated Regulator Circuit	Grounded I/O signals possible
Regulator Function	Speed or Torque selectable
Power Conversion	8 SCR Full Wave - Four Quadrant
Field Supply Protection	Full Wave MOV Voltage Transient Suppression High Interrupting Capacity Line Fuse
Speed Regulation	Armature or DC Tach Feedback
Line Start	Selectable for Auto-Restart
Controlled Stop	Provides Ramp to Stop Function
Zero Speed Deadband	Selectable 2% or Off
Zero Speed Indication	Open Collector – Active Low
Direction Indication	Open Collector – Active Low = FWD
Speed Regulator Node	External PID Input or Speed Trim
Speed Outputs	-10 – 10 VDC and 4 – 20 mA
Torque Outputs	-10 – 10 VDC and 4 – 20 mA
Diagnostic LED	Green Normal – Red Current Limit
Option Connector	Connects Additional Option Boards

### Control

Control Logic Power	24 VDC for Maintained Switch or Push button Operation
Speed Potentiometer	5 kOhms, ½ Watt
Input Reference	0 – 10 VDC or -10 – +10 VDC
Speed Regulation (95% Load Change)	2% with Armature Feedback 0.5% with Tachometer Feedback

### Adjustments

Maximum Speed	50% – 100% of Motor Base Speed
Current Limit FWD	0 – 150% of Full Load
Current Limit REV	0 – 150% of Full Load
IR Comp/Tach Scaling	0 – 10% IR or 0 – 100% Tach
Acceleration/Deceleration	0.1 – 30 Seconds
Voltage (Speed) Stability	Speed Gain Fine Tune
Current Stability FWD	Current Gain FWD Fine Tune
Current Stability REV	Current Gain REV Fine Tune

### Efficiency

Controller (only)	98%
With Motor (typical)	85%

### Approvals & Listings

UL and cUL

## DIMENSIONS

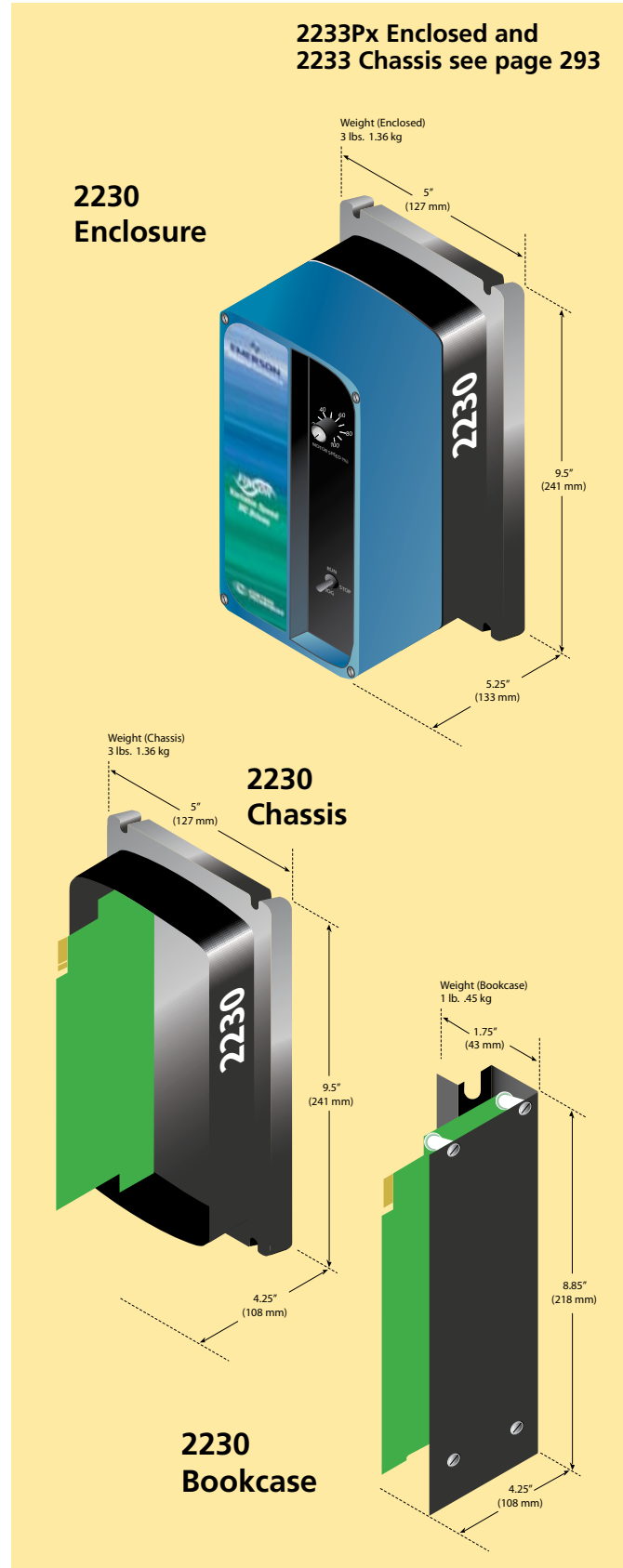

**TERMINAL DIAGRAM: Series 2230**

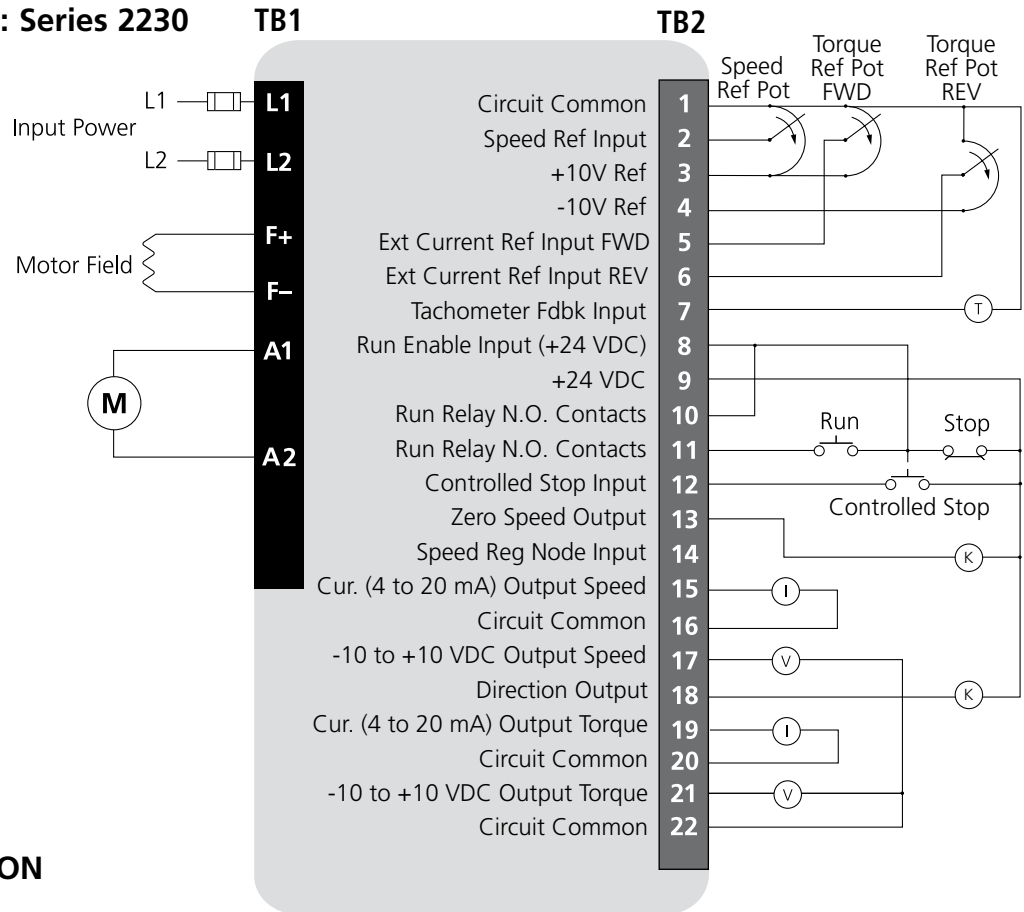

**TERMINAL DESCRIPTION**

**TB1**

Pin#	Type	Notes
L1	Line Voltage Input	115 or 230 VAC J1 Selectable
L2	Line Voltage Input	115 or 230 VAC J1 Selectable
F+	Field Voltage Output	+100 VDC @ 115 VAC or +200 VDC @230 VAC Input
F/2	Field Voltage (Half-Wave) Output	+50 VDC @ 115 VAC or +100 VDC @230 VAC Input
F-	Field Voltage Output	Field Minus Output
A1	Armature Output	-90 to +90 VDC @ 115 VAC or -180 to +180 VDC @ 230 VAC Input
A2	Armature Output	

**TB2**

Pin#	Type	Notes
1	Speed Reference Pot '0' End	Speed Pot Common for Unidirectional Operation
2	Speed Reference Input	200 KΩ Input Resistance
3	+10V Reference Output	5 mA max
4	-10V Reference Output	5 mA max
5	External Current Reference Input FWD	Refer to DIP Switch SW3-2
6	External Current Reference Input REV	Refer to DIP Switch SW3-7
7	Tachometer Input (Speed Feedback)	3-30 VDC, 31-175 VDC

**TB2 Continued**

Pin#	Type	Notes
8	Enable Input (+24 VDC) – Run Relay	24 VDC @ 6 mA Input
9	+24 VDC	For drive enable use only
10	Run Relay N.O. Contacts	Form A Contact Rated 0.5A @ 115 VAC or 2A @ 30 VDC
11	Run Relay N.O. Contacts	
12	Controlled Stop Input (+24 VDC)	Momentary +24 VDC Input to Initiate Controlled (Ramp) to Stop
13	Zero Speed Indication Output	Open Collector, Active Low, Rated 24 VDC @ 50ma
14	Speed Regulator Node Input	Speed Trim or External PID Input (Bypasses Accel/Decel Ramps)
15	Current Loop Output	4 to 20 mA – Speed (Arm Volts)
16	Current Loop Output	4 to 20 mA – Speed (Arm Volts)
17	Voltage Output	-10 to 10 VDC – Speed (Arm Volts)
18	Direction Indicator Output	Open Collector, Active Low for FWD; Rated 24 VDC @ 50 mA
19	Current Loop	Output 4 to 20 mA – Torque (Arm Amps)
20	Current Loop	
21	Voltage Output	-10 to 10 VDC – Load (Arm Amps)
22	Voltage Output Common	Isolated From Line – Can be connected to Earth