

EN

Base Drive Operation

The base EN drive can be easily controlled with single and multi-axis controllers, PLCs and host controllers for medium power applications. The analog torque or velocity modes can be used with classic position controllers using analog outputs and encoder inputs. The pulse mode is ideal for use with low-cost PLC stepper controllers. This drive works in a variety of applications where a host control provides a command signal determining the desired motion profile.

The EN Drive is configurable for seven flexible modes of operation, and the parameters for each mode can be adjusted to tailor the drive to the specific application using Windows™-based PowerTools FM software.

EN Series

Analog Torque Mode

Analog Velocity Mode

Digital Velocity Preset

Pulse Mode

- Pulse/Pulse
- Pulse/Direction
- Pulse/Quadrature

Summation of Analog Velocity and Digital Velocity

- **Programmable I/O**
 - 5 optically-isolated inputs (1 dedicated)
 - 3 optically-isolated outputs
 - 1 analog input ± 10 VDC, 14-bit
 - 2 analog output ± 10 VDC, 10-bit
 - Programmable encoder output, (up to 8,192 lines per revolution)
- Separate stop and travel limit decel ramps
- Torque, Travel, Following Error and velocity limits
- 8 user defined speed presets with individual accel/decel rates
- 2 Programmable Torque Level Outputs
- In Motion Velocity Output
- Auto-Tune
- Software Oscilloscope



STANDARD CONTROL MODES

Analog Velocity/Torque Mode

- MC
- Position Controller

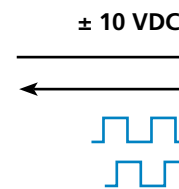

Digital Velocity Preset

- PLC
- User Logic



Pulse Mode

- PLC
- Master Axis
- Synchronized Encoder

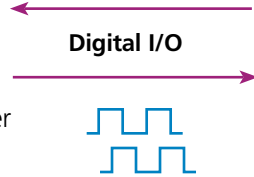

Summation of Analog Velocity and Digital Velocity

- PLC
- User Logic
- Analog Trim

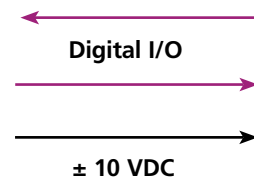

The operating mode of the drive is simply selected with one click in the PowerTools FM Detailed Setup tab.

PULSE MODE

In Pulse Mode the drive will receive pulses from a master source (single-ended or differential), which can be interpreted in three ways:

- Pulse/Pulse
- Pulse/Direction
- Pulse/Quadrature

Application Examples

- PLC pulse command outputs
- Electronic gearing
- Stepper drive replacement
- Web line ratio control

VELOCITY MODE

Analog— in Analog Velocity Mode the drive develops a velocity command in proportion to the voltage (± 10 VDC) received on the Analog Input. *Note: Analog full scale voltage and offset are programmable.*

Preset Velocity— In this mode one of up to eight digital velocities can be selected using the digital I/O or Modbus. Each preset has its own accel/decel ramps.

Application Examples

- Clutch-brake replacement
- Phase control with a differential
- Automatic feed control for machining operations
- Spindle speed control

Velocity Summation— This mode combines the features of Analog Velocity and Preset Velocity in one mode. It allows running a preset velocity and trimming it with an analog input, or vice versa, allowing advanced applications to be solved simply and elegantly without complex controllers.

Application Examples

- Loop/dancer arm control
- Phase advance/retard
- Speed trimming

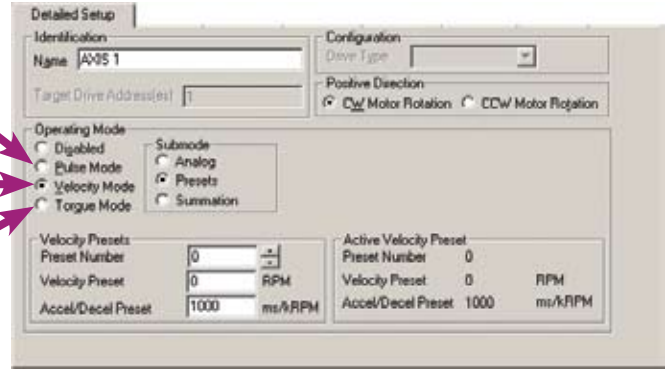

TORQUE MODE

In Analog Torque Mode the drive develops a torque command in proportion to the voltage (± 10 VDC) received in the Analog Input. *Note: Analog full scale voltage and offset are programmable.*

Application Examples

- With position/velocity controller
- Tension control

FLEXIBLE I/O FUNCTIONALITY

The digital I/O of the drive is completely programmable with the ability to map one or more I/O functions to the I/O points.

Input Functions

- Stop
- Reset
- Travel Limit (+)
- Travel Limit (-)
- Torque Limit Enable
- Torque Mode Enable
- Velocity Presets (3)
- Brake Release
- Brake Control

Output Functions

- Drive OK
- At Velocity
- Travel Limits (+)
- Travel Limits (-)
- In Motion (+)
- In Motion (-)
- Power Stage Enabled
- Torque Limit Active
- Velocity Limiting Active
- Fault
- Brake
- Shunt Active
- Torque Level 1 & 2 Active
- Foldback Active

EN with FM Modules

EN Series

FM control modules (see Controls) provide EN drives with “snap-on” functionality for Indexing (FM-2), Programming (FM-3E), and Advanced Programming (FM-4E). This modular approach allows users to choose the level of advanced machine control they need, based on the applications parameters and not the drive “spec”.

For applications requiring traditional multi-axis control, our MC controller is easily integrated with a single cable connection.

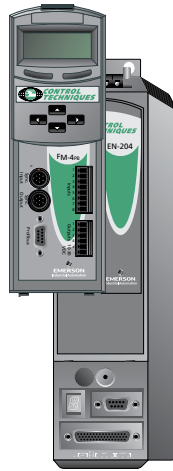

FM-2 INDEXING MODULE

The FM-2 module enhances EN drives by adding positioning capability including Jog, Home, Index functions including Position Tracker™ – Fieldbus Indexing. The FM-2 also includes additional I/O providing 8 digital inputs and 4 digital outputs.

FM-2 Application Examples

- Clutch-brake replacement
- Extend-retract arm
- Indexing table
- Indexing conveyor

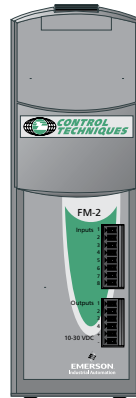

FM-3E PROGRAMMING MODULE

The FM-3E Ethernet module transforms the EN into a fully programmable single-axis motion controller, and adds 8 digital inputs and 4 digital outputs. Profibus (FM-3PB) and DeviceNet (FM-3DN) options are also available.

FM-3E Application Examples

- Tension control
- Flying cut off
- Auger filler
- Registration control
- Slip compensation



FM-4E ADVANCED PROGRAMMING MODULE

The FM-4E Advanced Programming module has taken all of the features and flexibility of the FM-3E, and added the ability to create complex motion profiles for sophisticated applications. The FM-4E adds versatility and extends functionality by including high speed data capture, summation of multiple motion profiles, program multi-tasking, and an array of parameters suitable for even the toughest applications. Profibus (FM-4PB) and DeviceNet (FM-4DN) options are also available.

FM-4E Application Examples

- Random infeed conveyor
- Merge conveyor
- Rotary knife
- High speed labeling
- Phase synchronization
- Electronic gearing
- Point-to-point positioning
- Thermoforming
- Web control

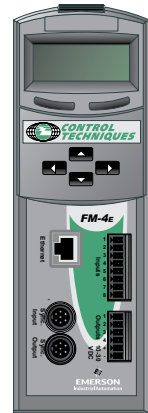

EN DRIVE TERMINALS AND PINOUTS

Serial (J4)	
Pin Number	Signal
3	RS232 TX
2	RS232 RX
6	Serial +5 VDC
5	Serial 0V Common
4	RS485+
9	RS485-
1	Shield
7,8	No Connect

Command (J5)	
Pin Number	Signal
15	Analog Command In +
14	Analog Command In -
8	Encoder Out A
9	Encoder Out A/
23	Encoder Out B
24	Encoder Out B/
37	Encoder Out Z
38	Encoder Out Z/
27	Pulse In A
41	Pulse In A/
26	Pulse In B
40	Pulse In B/
25	Pulse In Z
39	Pulse In Z/
20	Pulse In A (single ended)
36	Pulse In B (single ended)
16	I/O Input Drive Enable
1	I/O Input 1
2	I/O Input 2
3	I/O Input 3
4	I/O Input 4
19	I/O Output 1
18	I/O Output 2
17	I/O Output 3
33	I/O Supply +
34	I/O Supply +
31	I/O Supply 0V
32	I/O Supply 0V
29	Analog Out 0V
43	Analog Out Channel 1 +
44	Analog Out Channel 2 +
11	External Encoder +5VDC Power
12	External Encoder Common
28	+15V Power Out (10 mA)
6	RS485 +
21	RS485 -
5, 7, 10, 13, 22, 30, 35, 42	No Connect

Motor Power	
Terminal	Signal
PE	PE
R	Motor Power R
S	Motor Power S
T	Motor Power T

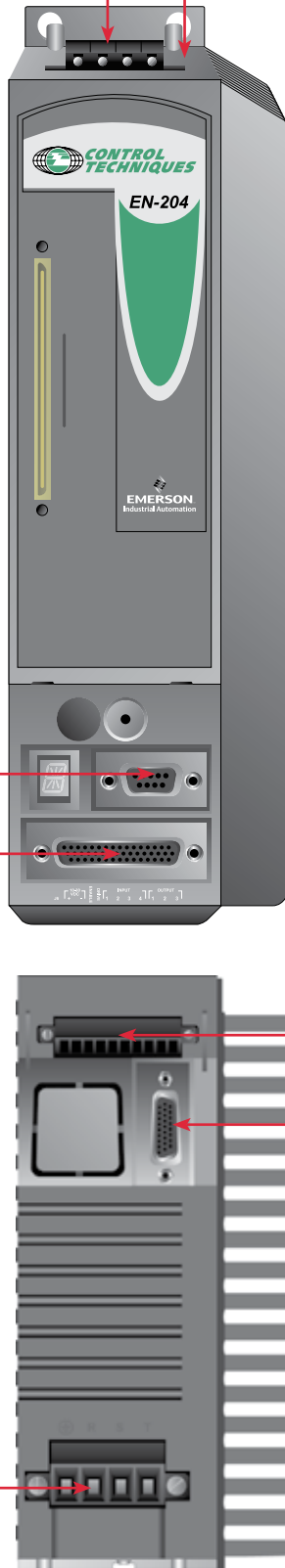

AC Power	
Terminal	Signal
L1	AC Input
L2	AC Input
L3	AC Input
PE	PE

Logic Backup Power (J3)	
Terminal	Signal
Aux 1	Logic Supply Backup +
Aux 2	Logic Supply Backup 0V Common

DC Power (J2)	
Terminal	Signal
Bus 1	DC Bus +
Bus 2	DC Bus -

Logic Backup Power and DC Power located on top beneath knock out not shown.

Digital I/O (J6)	
Pin Number	Signal
1	I/O Supply +
2	I/O Supply 0V
3	Drive Enable
4	Input 1
5	Input 2
6	Input 3
7	Input 4
8	Output 1
9	Output 2
10	Output 3

Feedback (J7)	
Pin Number	Signal
1	Motor Encoder A
10	Motor Encoder A/
2	Motor Encoder B
11	Motor Encoder B/
3	Motor Encoder Z
12	Motor Encoder Z/
4	Motor Commutation U
13	Motor Commutation U/
5	Motor Commutation V
14	Motor Commutation V/
6	Motor Commutation W
15	Motor Commutation W/
7,8	Encoder +5 VDC Supply
17	Encoder 0V Common
9	Motor OverTemp
16,18-26	No Connect

EN Series

HOW TO ORDER

Depending on your motor selection, use one of the next few pages to configure a basic EN system by selecting one item from each of the four ordering columns, and the fifth column if you are choosing a brake motor. Note that item ② motor selection requires additional input as to flange, and on NT systems connector type. (See the Motor Order String boxes for details.) Items ③ through ⑤ require cable lengths to be provided. The basic systems represented on these pages can be customized with a variety of components depending on your needs. A guide to EN options and accessories can be found at the end of this page.

SELECT SYSTEM AND MOTOR

- ① Select the EN drive appropriate to the needs of your application.
- ② Select a performance matched motor for your drive. The system selection matrix for motors is found on the following page.

CABLE ORDERING OPTIONS

Motor power, feedback and brake cables use MS style connectors and are fully shielded with IP65 molded connectors and are available in standard and custom lengths. For more information on these and other cables, see the *Options and Accessories* section.

Standard lengths of 5, 15, 25, 50 and 100 feet are available from stock. Non-standard lengths require additional lead time. **Note: Equivalent FM Motor cable lengths are in meters.**

Feet=xxx or meters=yyy with specified lengths. Example: 005 = 5 feet. For applications involving continuous flexing, flexible cables are available. Cable components such as connector kits and raw cable are also available. See the *Options and Accessories* section for details or consult factory for special requirements.

- ③ **Motor Power Cables Example;**
CMDS-xxx 16 AWG for 2-3" motors or CMMS-xxx 12 AWG for 4" motors, both cables have connectors on the motor end and ferrules on the drive end.
- ④ **Motor Feedback Cables Example;**
CFCS-xxx Connectors on both ends.
- ⑤ **Motor Brake Cable Example;**
CBMS-xxx Required for all motors with brake option; connector on motor end only.

Software is Free!

The Control Techniques' "Motion Made Easy" Power CD (CT-MME-POWER-CD) is shipped with every product. Software updates are free and can be downloaded from our web site, as are firmware updates.



EN OPTIONS AND ACCESSORIES

Control Techniques provides a complete array of options and accessories to complete your system. For details, see the Options and Accessories section of the catalog.

Brake Relays

BRM-1

Breakout Board

ECI-44, DEMO-FMIO-000, DEMO-DRIO-000

Diagnostics

DGNE

Auxiliary Logic Supplies

ALP-130, ALP-430

External Shunts/Resistors

(see Power Accessories)

AC Line Filters

960304-01 (EN-214), 960305-01 (EN-204, EN-208)

Synchronization Encoders

SCSLD-4, SCSLD-4R

Operator Interface

CTVue, OIT, CTIU

Extended Warranty

Extends Two Year Warranty to Five Years

EN Series 230V FM Motor

The FM 230V line is a medium to high inertia line for larger load applications. It is designed to allow use in many applications and offers a wide range of options. The FM line is offered in metric frame sizes, 75 mm, 95 mm, 115 mm, 142 mm and 190 mm. The standard configured motor has a 4096 line encoder, vertical connectors and non-brake. This configuration is designed with low cogging torque to provide smooth operation and excellent velocity regulation. The torque range available is 19.8 lb-in (2 Nm) to 214 lb-in (24.2 Nm). All models are rated IP65.

The FM motor is also available with many other options like resolver and Sin/Cos feedback, NEMA flange, different shaft diameters, 90° and rotatable connectors, and a high peak torque option that allows intermittent operation near 5 times their continuous torque levels.

Order String

xxx	E	2	x	xx	x	B	A	CA	A	BCD*	DIA*
-----	---	---	---	----	---	---	---	----	---	------	------

↑

Frame Size: 075, 095, 115, 142, 190

↑

Voltage E = 230V

↑

Peak Torque: 2 = Standard Peak Torque

↑

Stator Length: A, B, C, D, E, F, G, H

↑

Rated Speed: 20 = 2,000 rpm, 30 = 3,000 rpm, 40 = 4,000 rpm, 50 = 5,000 rpm

↑

Brake: 0 = None, 1 = 24 VDC

↑

Connection Type: B = 90° Connectors

↑

Shaft Key: A = With Key

↑

Feedback Device: CA = 4096 Incremental Encoder

↑

Inertia: A = Standard

* Bolt Circle & Shaft Diameter are standard dimensions see FM Motor section for additional options.

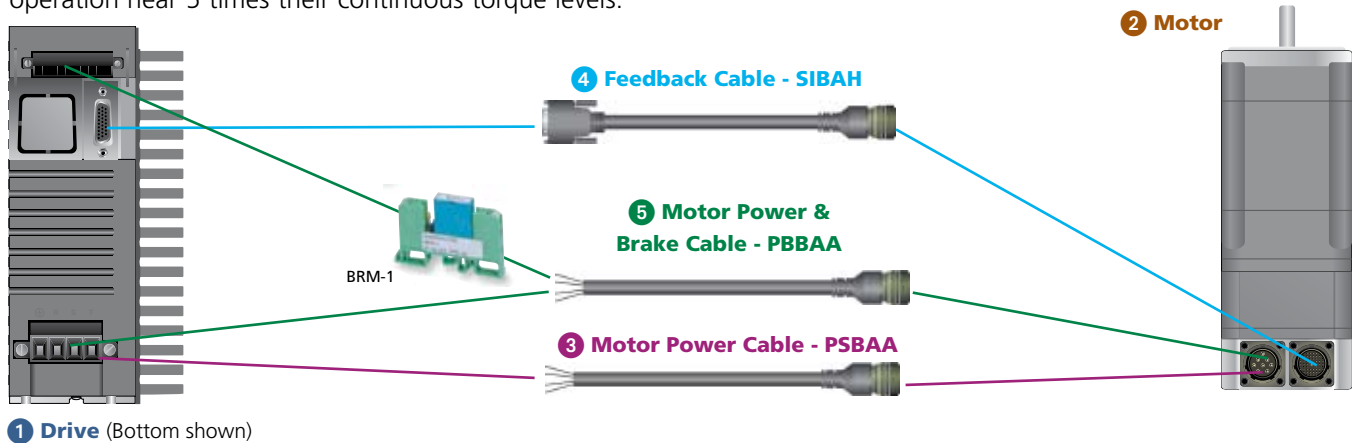

Servo System Order Guide

Note: Cable lengths in meters.

① Drive Model	② Motor Model	③ Motor Power Cable (yyy=meters)	④ Feedback Cable (yyy=meters)	⑤ Motor Power/Brake Cable (required w/all brake motors) (yyy=meters)
EN-204	075E2B400 BACAA075140	PSBAA-yyy	SIBAH-yyy	
	075E2B401 BACAA075140		SIBAH-yyy	PBBAA-yyy
	075E2D300 BACAA075140	PSBAA-yyy	SIBAH-yyy	
	075E2D301 BACAA075140		SIBAH-yyy	PBBAA-yyy
EN-208	095E2D400 BACAA100190	PSBAA-yyy	SIBAH-yyy	
	095E2D401 BACAA100190		SIBAH-yyy	PBBAA-yyy
	095E2E300 BACAA100190	PSBAA-yyy	SIBAH-yyy	
	095E2E301 BACAA100190		SIBAH-yyy	PBBAA-yyy
EN-214	095E2D400 BACAA100190	PSBAA-yyy	SIBAH-yyy	
	095E2D401 BACAA100190		SIBAH-yyy	PBBAA-yyy
	115E2C300 BACAA115190	PSBAA-yyy	SIBAH-yyy	
	115E2C301 BACAA115190		SIBAH-yyy	PBBAA-yyy
	115E2E300 BACAA115240	PSBAA-yyy	SIBAH-yyy	
	115E2E301 BACAA115240		SIBAH-yyy	PBBAA-yyy

EN - 230V FM Motor Specifications

Drive Model	Motor Model	Cont. Stall Torque lb-in Nm	Peak Stall Torque lb-in Nm	Rated Torque @Rated Speed* lb-in Nm	Rated Power HP kWatts	Max.* Operating Speed RPM	Encoder Resolution lines/rev	Inertia lb-in-sec ² kg-cm ²	Motor Ke Vrms/krpm	Motor Kt lb-in/Arms Nm/Arms	Motor Weight lb kg
EN-204	075E2B400	19.75	57.35	15.05	0.95	4000	4096	0.001062	44	6.37	9.7
		2.23	6.48	1.70	0.71					1.2	0.72
EN-204	075E2D300	34.57	74.07	30.98	1.47	3000	4096	0.00177	57	8.23	13.2
		3.91	8.37	3.50	1.10					2	0.93
EN-208	095E2D400	57.35	114.70	43.37	2.73	4000	4096	0.004514	44	6.37	19.1
		6.48	12.96	4.90	2.05			5.1		0.72	8.7
EN-214	095E2D400	66.91	165.67	43.37	2.73	4000	4096	0.004514	44	6.37	19.1
		7.56	18.72	4.90	2.05			5.1		0.72	8.7
EN-208	095E2E300	74.07	148.15	71.69	3.39	3000	4096	0.005487	57	8.23	21.8
		8.37	16.74	8.10	2.54			6.2		0.93	9.9
EN-214	115E2C300	83.95	213.99	71.69	3.39	3000	4096	0.007965	57	8.23	25.5
		9.49	24.18	8.10	2.54			9		0.93	11.6
EN-214	115E2E300	107.00	213.99	107.00	5.07	3000	4096	0.012213	57	8.23	33.9
		12.09	24.18	12.09	3.80			13.8		0.93	15.4

*Rated Speed = Maximum Operating Speed

EN - 230V FM Motor Speed Torque Curves

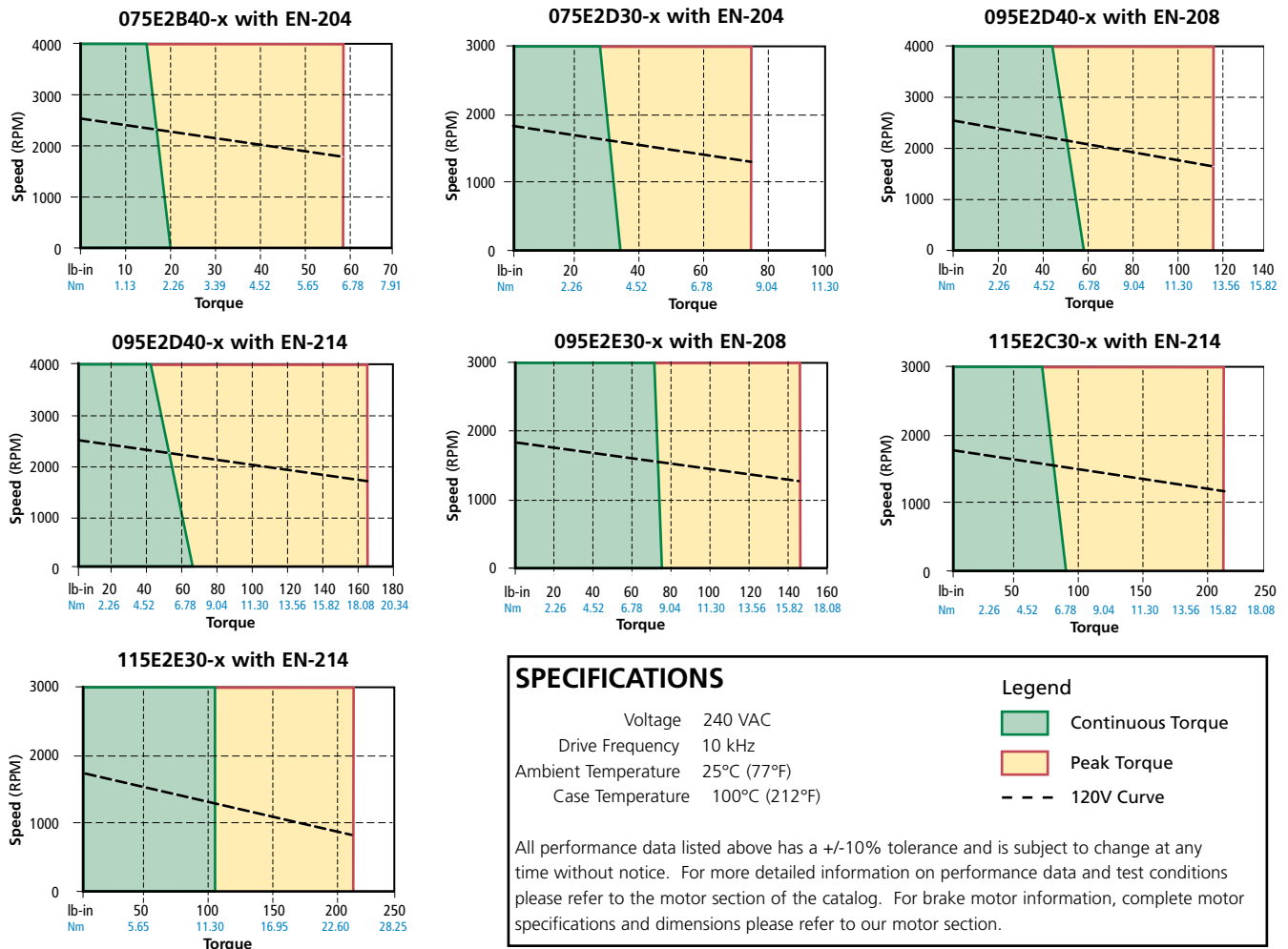

EN Series

230V NT Motor Selection

The NT motor is a high performance motor utilizing patented technology to maximize torque in a compact package. The NT motor uses powerful Neodymium magnets and is manufactured with a segmented core to maximize stator efficiency. The NT motor has a very low inertia for applications that demand high accel and cycle rates. NT motors are available in English (NEMA 23 or 34) or Metric (IEC-72-1) flanges, with or without brakes. The standard encoder resolution is 2048 lines per rev. NT motors can be ordered with MS style connectors, 1 m Flying Leads, or 1 m Flying Leads with MS connectors.

Order String

NT	x	x	xx	x	x	N	S	0000
↑	↑	↑	↑	↑	↑	↑	↑	↑

Special Options: DSXX = DSUB
 Inertia: S = Standard, I = Medium
 N = Encoder Feedback Type: Encoder
 Brake Option: B = with Brake, O = No Brake
 Connector Type:
 C = MS connectors on motor
 T = MS connectors on one meter leads
 L = one meter leads without connectors
 Continuous Torque (lb-in): 7, 12, 20, 30, 45 or 55
 Frame Size (in inches): 2 or 3
 Mounting Flange: E = English, M = Metric
 NT Motor Family

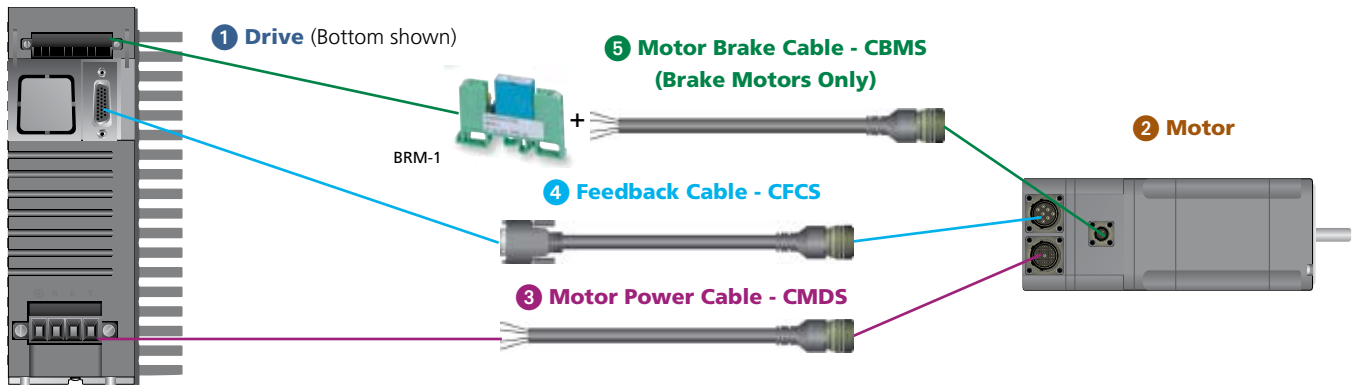

For additional motor information see Motors.
For additional cable options see Options.

Servo System Order Guide

① Drive Model	② Motor Model (x=Flange type; y=Connector type)	③ Motor Power Cable (xxx=feet)	④ Feedback Cable (xxx=feet)	⑤ Motor Brake Cable (required w/all brake motors) (xxx=feet)
EN-204-00-000	NTx-207-yONS-0000	CMDS-xxx	CFCs-xxx	
	NTx-207-yBNS-0000	CMDS-xxx	CFCs-xxx	CBMS-xxx
	NTx-212-yONS-0000	CMDS-xxx	CFCs-xxx	
	NTx-212-yBNS-0000	CMDS-xxx	CFCs-xxx	CBMS-xxx
EN-208-00-000	NTx-320-yONS-0000	CMDS-xxx	CFCs-xxx	
	NTx-320-yBNS-0000	CMDS-xxx	CFCs-xxx	CBMS-xxx
	NTx-330-yONS-0000	CMDS-xxx	CFCs-xxx	
	NTx-330-yBNS-0000	CMDS-xxx	CFCs-xxx	CBMS-xxx
	NTx-345-yONS-0000	CMDS-xxx	CFCs-xxx	
	NTx-345-yBNS-0000	CMDS-xxx	CFCs-xxx	CBMS-xxx
	NTx-355-yONS-0000	CMDS-xxx	CFCs-xxx	
NTx-355-yBNS-0000	CMDS-xxx	CFCs-xxx	CBMS-xxx	
EN-214-00-000	NTx-345-yONS-0000	CMDS-xxx	CFCs-xxx	
	NTx-345-yBNS-0000	CMDS-xxx	CFCs-xxx	CBMS-xxx
	NTx-355-yONS-0000	CMDS-xxx	CFCs-xxx	
	NTx-355-yBNS-0000	CMDS-xxx	CFCs-xxx	CBMS-xxx

EN - 230V NT Motor Specifications

Drive Model	Motor Model	Cont. Stall	Peak Stall	Rated Torque	Rated	Max.*	Encoder Resolution	Inertia	Motor Ke	Motor Kt	Motor Weight
		Torque	Torque	@Rated Speed*	Power	Operating					
		lb-in	lb-in	lb-in	HP	Speed	lines/rev	lb-in-sec ²	Vrms/krpm	lb-in/Arms	lb
		Nm	Nm	Nm	kWatts	RPM		kg-cm ²		Nm/Arms	kg
EN-204	NT-207	7.5 0.85	15 1.72	7.5 0.85	0.60 0.44	5000	2048	0.000094 0.106	35	5.12 0.58	3 1.36
EN-204	NT-212	12.5 1.41	27 3.05	12 1.4	1.03 0.77	5000	2048	0.000164 0.185	35	5.12 0.58	4 1.82
EN-208	NT-320	20 2.22	38 4.24	16 1.81	1.02 0.76	4000	2048	0.000328 0.370	29	3.50 0.40	6 2.72
EN-208	NT-330	27 3.05	58 6.55	27 3.05	1.71 1.28	4000	2048	0.000438 0.494	36	4.73 0.53	7.3 3.31
EN-208	NT-345	42 4.75	80 9.04	42 4.75	2.00 1.49	3000	2048	0.000668 0.754	50	6.37 0.72	10 4.54
EN-208	NT-355	48 5.42	90 10.17	48 5.42	2.28 1.71	3000	2048	0.000888 1.0	50	6.32 0.71	12.3 5.58
EN-214	NT-345	42 4.75	94 10.62	42 4.75	2.00 1.49	3000	2048	0.000668 0.754	50	6.37 0.72	10 4.54
EN-214	NT-355	48 5.42	116 13.10	48 5.42	2.28 1.71	3000	2048	0.000888 1.0	50	6.32 0.71	12.3 5.58

* Rated Speed = Maximum Operating Speed

EN - 230V NT Motor Speed Torque Curves

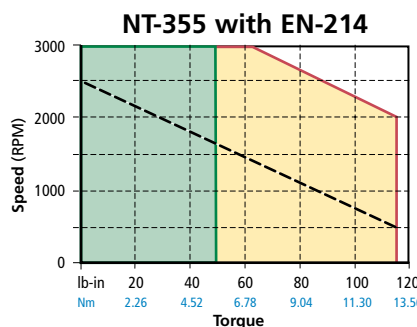
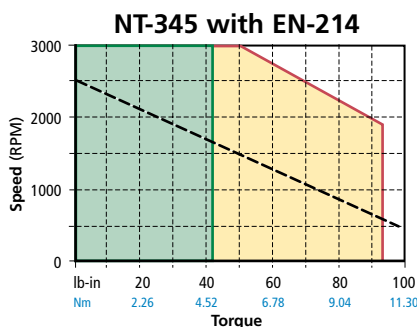
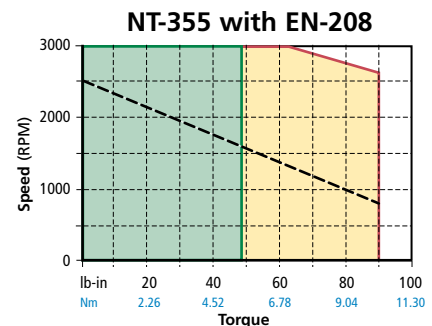
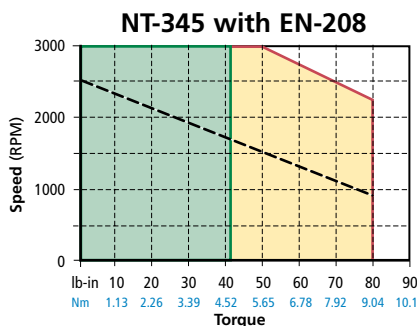
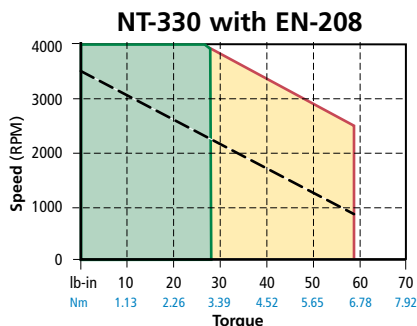
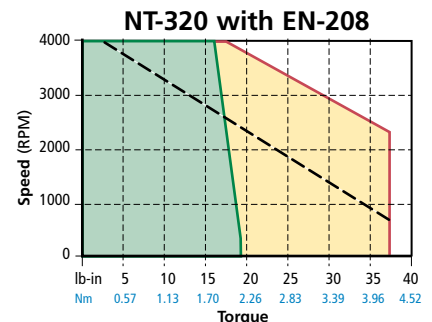
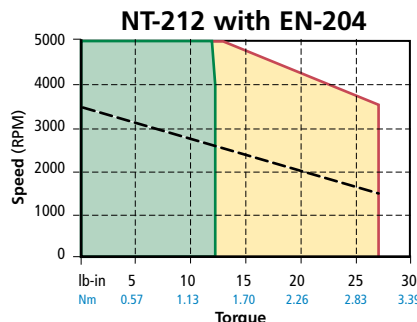
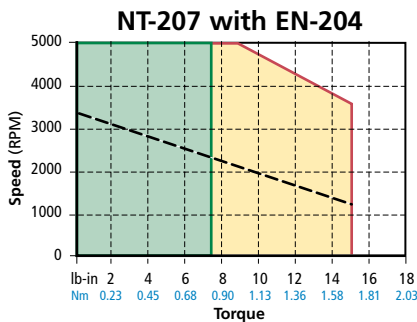

SPECIFICATIONS

- Voltage 240 VAC
- Drive Frequency 20 kHz
- Ambient Temperature 25°C (77°F)
- Case Temperature 100°C (212°F)

All performance data listed above has a +/-10% tolerance and is subject to change at any time without notice. For more detailed information on performance data and test conditions please refer to the motor section of the catalog. For brake motor information, complete motor specifications and dimensions please refer to our motor section.

* Dashed line equals 120V curve

EN Series

230V MG Motor Selection

The MG motor is a low inertia motor that is great for dynamic applications that have larger load inertias. MG motors use Neodymium magnets to achieve a high torque to inertia ratio giving them a size advantage when compared to competitors motors. MG motors are available in English (NEMA 23, 34, or 56) and Metric (IEC-72-1) flanges, with or without brakes. The standard encoder resolution is 2048 lines per rev. MG motors come standard with MS style connectors. For applications that require custom motors the MG line is the choice.

Order String

MG x x xx C x N S 0000

↑

MG Motor Family

↑

Mounting Flange: E = English, M = Metric

↑

Frame Size (in inches): 2, 3 or 4

↑

Continuous Torque (lb-in): 5, 8, 16, 40, 55, 90 or 120

↑

Connector Type:
C = MS connectors on motor

↑

Brake Option: B = with Brake,
O = No Brake

↑

N = Encoder Feedback Type: Encoder

↑

S = Shaft Seal (Standard)

↑

Special Options

EN Series

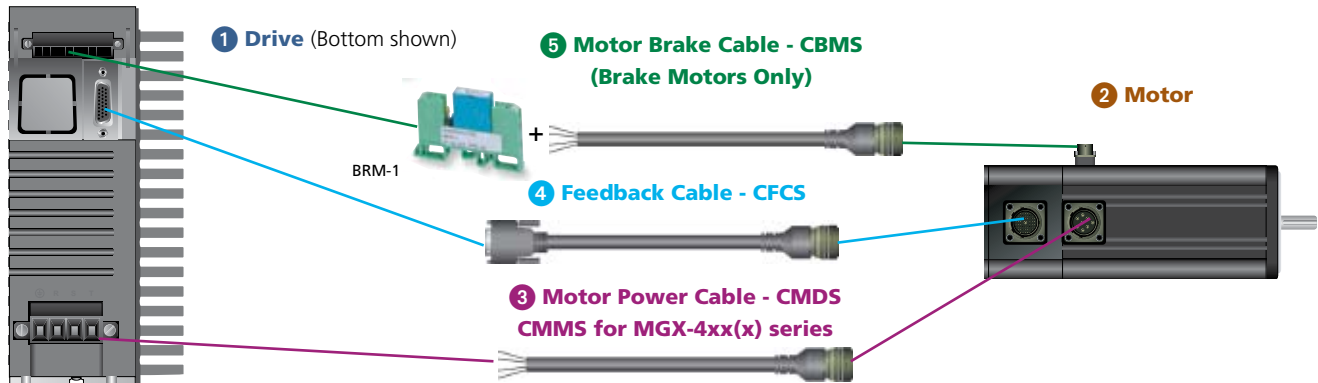

For additional motor information see Motors.
For additional cable options see Options.

Servo System Order Guide

① EN Servo Drive	② MG Servo Motor (x=Flange type)	③ Motor Power Cable (xxx=feet)	④ Feedback Cable (xxx=feet)	⑤ Motor Brake Cable (required w/ all brake motors) (xxx=feet)
EN-204-00-000	MGx-205-CONS-0000	CMDS-xxx	CFCS-xxx	
	MGx-205-CBNS-0000	CMDS-xxx	CFCS-xxx	CBMS-xxx
	MGx-208-CONS-0000	CMDS-xxx	CFCS-xxx	
	MGx-208-CBNS-0000	CMDS-xxx	CFCS-xxx	CBMS-xxx
	MGx-316-CONS-0000	CMDS-xxx	CFCS-xxx	
	MGx-316-CBNS-0000	CMDS-xxx	CFCS-xxx	CBMS-xxx
EN-208-00-000	MGx-316-CONS-0000	CMDS-xxx	CFCS-xxx	
	MGx-316-CBNS-0000	CMDS-xxx	CFCS-xxx	CBMS-xxx
	MGx-340-CONS-0000	CMDS-xxx	CFCS-xxx	
	MGx-340-CBNS-0000	CMDS-xxx	CFCS-xxx	CBMS-xxx
	MGx-455-CONS-0000	CMMS-xxx	CFCS-xxx	
	MGx-455-CBNS-0000	CMMS-xxx	CFCS-xxx	CBMS-xxx
EN-214-00-000	MGx-455-CONS-0000	CMMS-xxx	CFCS-xxx	
	MGx-455-CBNS-0000	CMMS-xxx	CFCS-xxx	CBMS-xxx
	MGx-490-CONS-0000	CMMS-xxx	CFCS-xxx	
	MGx-490-CBNS-0000	CMMS-xxx	CFCS-xxx	CBMS-xxx
	MGx-4120-CONS-0000	CMMS-xxx	CFCS-xxx	
	MGx-4120-CBNS-0000	CMMS-xxx	CFCS-xxx	CBMS-xxx

EN - 230V MG Motor Specifications

Drive Model	Motor Model	Cont. Stall Torque lb-in Nm	Peak Stall Torque lb-in Nm	Rated Torque @Rated Speed* lb-in Nm	Rated Power HP kWatts	Max.* Operating Speed RPM	Encoder Resolution lines/rev	Inertia lb-in-sec ² kg-cm ²	Motor Ke Vrms/krpm	Motor Kt lb-in/Arms Nm/Arms	Motor Weight lb kg
EN-204	MG-205	5 0.56	16 1.81	3.7 0.41	0.29 0.22	5000	2048	0.000099 0.112	28	4.1 0.47	3 1.3
EN-204	MG-208	9 1.02	27 3.09	7.5 0.848	0.60 0.44	5000	2048	0.000169 0.191	28	4.1 0.47	4 1.8
EN-204	MG-316	18.6 2.10	42 4.75	16 1.81	1.02 0.76	4000	2048	0.000560 0.630	38	5.5 0.62	8.3 3.8
EN-208	MG-316	18.6 2.10	56 6.33	16 1.81	1.02 0.76	4000	2048	0.000560 0.630	38	5.5 0.62	8.3 3.8
EN-208	MG-340	50 5.65	133 15.03	42 4.75	2.00 1.49	3000	2048	0.001458 1.646	57	8.3 0.94	14.6 6.6
EN-208	MG-455	68 7.68	138 15.40	52 5.84	2.48 1.85	3000	2048	0.002658 3.000	60	8.8 0.99	20 9.1
EN-214	MG-455	68 7.68	200 22.60	52 5.84	2.48 1.85	3000	2048	0.002658 3.000	60	8.8 0.99	20 9.1
EN-214	MG-490	100 11.30	217 24.50	80 9.04	3.81 2.84	3000	2048	0.005175 5.823	59	8.6 0.97	26.8 13
EN-214	MG-4120	132 14.90	256 28.90	120 13.56	5.71 4.26	3000	2048	0.007458 8.4	72	10.5 1.19	37 16.8

* Rated Speed = Maximum Operating Speed

EN - 230V MG Motor Speed Torque Curves

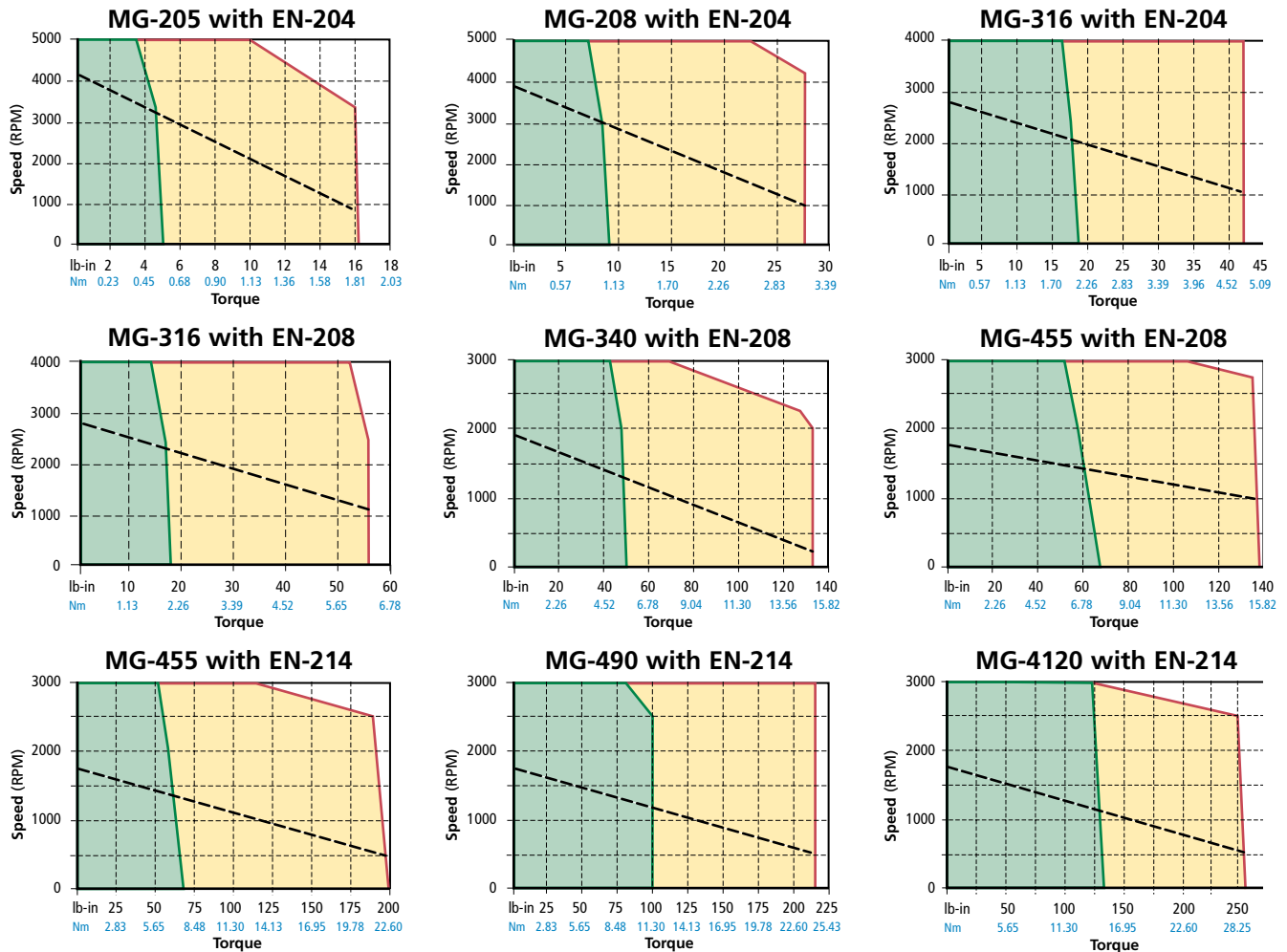

Dashed line equals 120V curve.

EN Series

230V XV Motor

The new XV Servo Motor line delivers high-performance, low inertia, and high torque in a compact motor package. It offers a low cost solution with the features of a premium priced servo offering. Intended for higher throughputs and smaller machines, XV motors are available in 4 frame sizes: 40, 60, 80 and 130 mm with speeds ranging from 2000 to 5000 RPM.

Applications with continuous torque requirements up to 101 lb-in (11.4 Nm) are the perfect match for the XV motors. The XV motor series is CE, UL and RoHS approved.

Order String

XV	M	xxx	xxx	x	x	N	S	0000
↑	↑	↑	↑	↑	↑	↑	↑	↑

Special Options

S = Standard

N = Incremental Encoder

Brake Option: B = with Brake, O = No Brake

Connector Type:

C = MS connectors on motor

T = Flying Lead with Connectors

Continuous Torque (lb-in): 1, 3, 6, 11, 17, 23, 28, 46, 51, 68, 89 or 101

Frame Size (in millimeters): 40, 60, 80 or 130

Mounting Flange: M = Metric

XV Motor Family

For additional motor information see Motors.
For additional cable options see Options.

EN Series

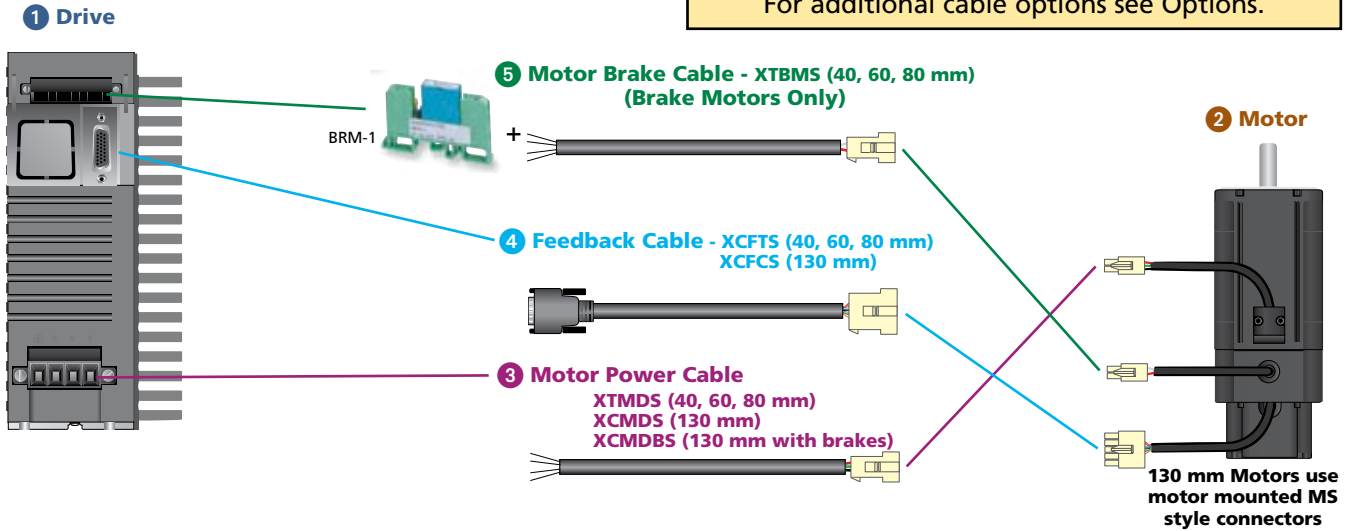

Servo System Order Guide

EN Series

1 EN Servo Drive	2 XV Servo Motor*	3 Motor Power Cable (xxx=feet)	4 Feedback Cable (xxx=feet)	5 Motor Brake Cable (required w/all brake motors) (xxx=feet)	
EN-204-00-000	XVM-6011-TONS-0000	XTMDS-xxx	XCFTS-xxx	XTBMS-xxx	
	XVM-6011-TBNS-0000	XTMDS-xxx	XCFTS-xxx		
	XVM-8017-TONS-0000	XTMDS-xxx	XCFTS-xxx	XTBMS-xxx	
	XVM-8017-TBNS-0000	XTMDS-xxx	XCFTS-xxx		
	XVM-8023-TONS-0000	XTMDS-xxx	XCFTS-xxx	XTBMS-xxx	
	XVM-8023-TBNS-0000	XTMDS-xxx	XCFTS-xxx		
EN-208-00-000	XVM-8028-TONS-0000	XTMDS-xxx	XCFTS-xxx	XTBMS-xxx	
	XVM-8028-TBNS-0000	XTMDS-xxx	XCFTS-xxx		
EN-214-00-000	XVM-13051-CONS-0000	XCMD5-xxx	XCFC5-xxx	Combination Cable	
	XVM-13051-CBNS-0000	XCMD5B-xxx **	XCFC5-xxx		
	EN-208-00-000	XVM-13046-CONS-0000	XCMD5-xxx	XCFC5-xxx	Combination Cable
		XVM-13046-CBNS-0000	XCMD5B-xxx **	XCFC5-xxx	
EN-214-00-000	XVM-13089-CONS-0000	XCMD5-xxx	XCFC5-xxx	Combination Cable	
	XVM-13089-CBNS-0000	XCMD5B-xxx **	XCFC5-xxx		
EN-214-00-000	XVM-130101-CONS-0000	XCMD5-xxx	XCFC5-xxx	Combination Cable	
	XVM-130101-CBNS-0000	XCMD5B-xxx **	XCFC5-xxx		
	XVM-13068-CONS-0000	XCMD5-xxx	XCFC5-xxx		

*Rated Speed = Maximum Operating Speed
 ** Combination Motor Power and Brake Cable

EN - 230V XV Motor Specifications

Drive Model	Motor Model	Cont. Torque lb-in	Peak Stall Torque lb-in	Rated Torque @Rated Speed* lb-in	Rated Power HP	Max.* Operating Speed RPM	Encoder Resolution lines/rev	Inertia lb-in-sec ²	Motor Ke Vrms/krpm	Motor Kt lb-in/Arms	Motor Weight lb
		Nm	Nm	Nm	kWatts			kg-cm ²		Nm/Arms	kg
EN-204	XV-6011	11.24	32.3	11.24	0.54	5000	2048	0.000	29.5	4.15	3.5
		1.27	3.65	3.65	0.40			0.321	0.47	1.63	
EN-204	XV-8017	16.9	42.5	16.9	0.80	5000	2048	0.001	35.2	5	5.4
		1.91	4.8	1.91	0.60			1.092	0.57	2.49	
EN-204	XV-8023	23.3	54.9	23.3	0.74	3000	2048	0.001	44.6	6.32	6.9
		2.63	6.2	2.63	0.55			1.59	0.71	3.15	
EN-204	XV-8028	23.6	47.1	23.6	1.12	5000	2048	0.002	39.2	5.57	8.3
		2.67	5.32	2.67	0.84			1.97	0.63	3.8	
EN-204	XV-13051	50.7	110	50.7	0.80	2000	2048	0.011	85.8	12.87	15.8
		5.73	12.4	5.73	0.60			11.99	1.45	7.2	
EN-208	XV-8028	28.1	81.1	28.1	1.34	5000	2048	0.002	39.2	5.57	8.3
		3.18	9.16	3.18	1.00			1.927	0.63	3.8	
EN-208	XV-13046	46.5	133.3	46.5	1.48	3000	2048	0.011	53.1	7.71	15.8
		5.25	15.1	5.25	1.10			11.99	0.87	7.2	
EN-208	XV-13089	88.76	236.7	88.76	1.40	2000	2048	0.015	94.6	15.57	21.3
		10.03	26.7	10.03	1.05			17.34	1.76	9.7	
EN-208	XV-130101	101.4	239.2	101.4	1.61	2000	2048	0.020	90	13.88	22.4
		11.46	27	11.46	1.20			22.68	1.57	10.2	
EN-214	XV-13068	67.6	190.4	67.6	2.15	3000	2048	0.015	54.2	7.59	19.1
		7.64	21.5	7.64	1.60			17.34	0.86	8.7	
EN-214	XV-13089	88.76	260.4	88.76	1.40	2000	2048	0.015	94.6	15.57	21.3
		10.03	29.4	10.03	1.05			17.34	1.76	9.7	
EN-214	XV-130101	101.4	296.4	101.4	1.61	2000	2048	0.020	90	13.88	22.4
		11.46	34.5	11.46	1.20			22.68	1.57	10.2	

*Rated Speed = Maximum Operating Speed

EN - 230V XV Motor Speed Torque Curves

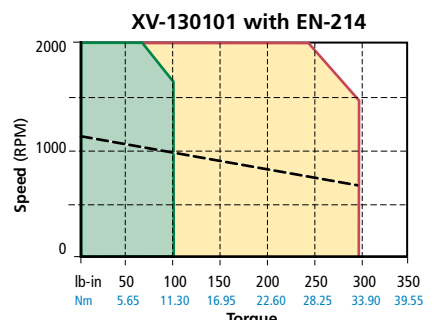
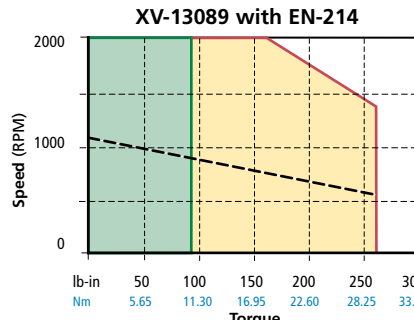
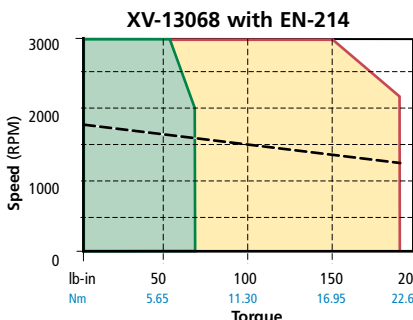
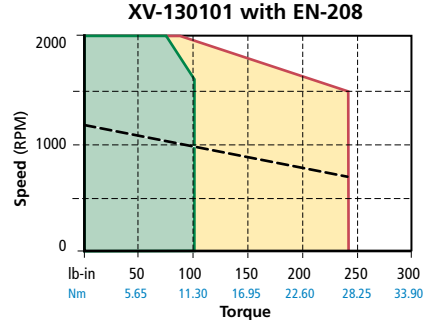
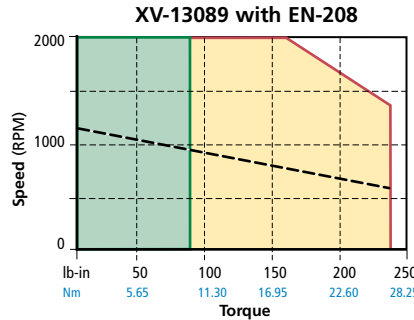
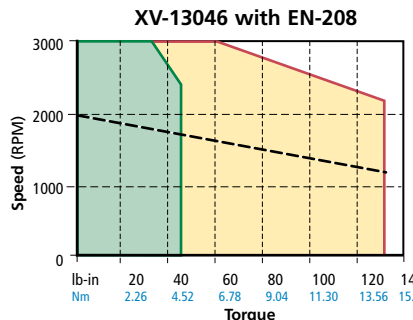
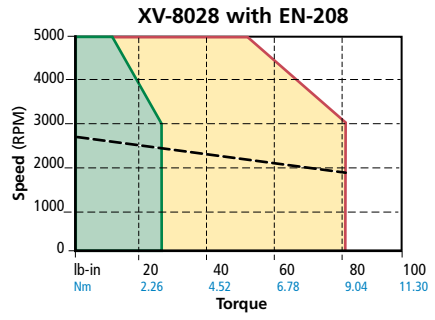
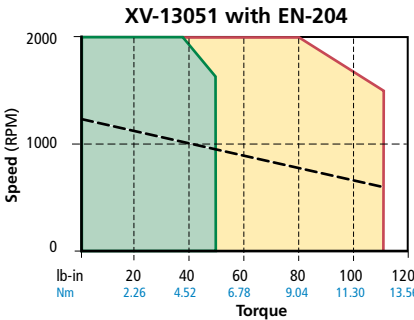
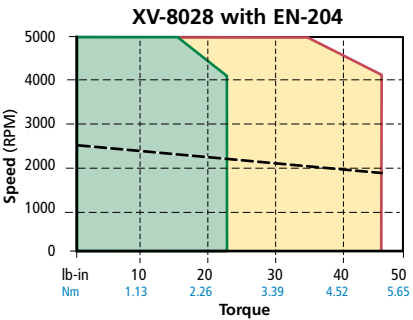
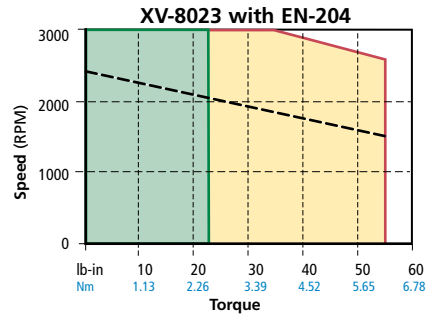
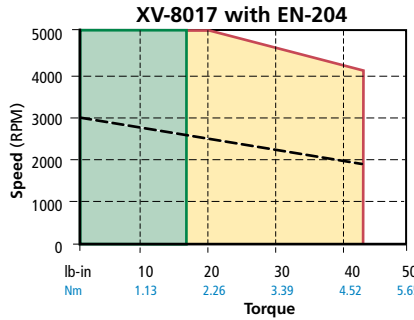
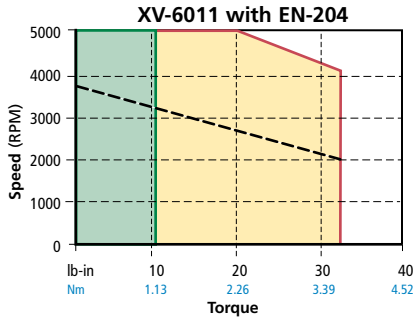

SPECIFICATIONS

Voltage 240 VAC
 Drive Frequency 10 kHz
 Ambient Temperature 25°C (77°F)
 Case Temperature 75°C (167°F)

Legend

- - - 120V Curve
- Green shaded area Continuous Torque
- Yellow shaded area Peak Torque

All performance data listed above has a +/-10% tolerance and is subject to change at any time without notice. For more detailed information on performance data and test conditions please refer to the motor section of the catalog. For brake motor information, complete motor specifications and dimensions please refer to our motor section.

EN SPECIFICATIONS AND DIMENSIONS

Power Requirements

AC Input Voltage: 90 to 264 VAC, 47 - 63 Hz
(230 VAC for rated performance)

- EN-204: 1Ø
- EN-208: 1Ø
- EN-214: 3Ø (For 1Ø, derate output current by 20%)

AC Input Current:

- EN-204: 9.5 Arms (140A for 8 ms inrush)
- EN-208: 19 Arms (140A for 8 ms inrush)
- EN-214: 20 Arms, 1Ø (140A for 5 ms inrush)
- EN-214: 14 Arms, 3Ø (100A for 5 ms inrush)

Output Continuous Current (RMS):

- EN-204: 4.5 Arms
- EN-208: 9 Arms
- EN-214: 13 Arms (For 1Ø, derate by 20%)

Output Peak Current:

- EN-204: 9A
- EN-208: 18A
- EN-214: 26A (For 1Ø, derate by 20%)

Continuous Output Power:

- EN-204: 1.8 kW
- EN-208: 3.6 kW
- EN-214: 5.2 kW

Switching Frequency 20 kHz

Logic Supply Internal

Alternate Logic Supply +127 to 373 VDC, 22W

Encoder Supply Output +5 VDC, 250 mA

Efficiency 93%

Regeneration

Internal Energy Absorption (230V):

- EN-204: 79 Joules
- EN-208: 50 W Resistor plus 79 Joules
- EN-214: 50 W Resistor plus 79 Joules

Internal Energy Absorption (115V):

- EN-204: 150 Joules
- EN-208: 50 W Resistor plus 150 Joules
- EN-214: 50 W Resistor plus 150 Joules

External: Connection to RSR-2 with external resistor, 20 Ohm min, 15 Arms, 2 kW

Drive Control Inputs

- Analog: (1) +/- 10 VDC 14 bit, 100 kOhm, Differential
- Analog Max Input Rating: Differential +/- 14 VDC, Each Input with Reference to Analog Ground +/- 14 VDC
- Digital: (5) +10 to 30 VDC, 2.8 kOhm, Sourcing, Optically isolated
- Pulse: (1) Differential: RS422, 2 MHz/ Channel, 50% Duty Cycle
- Single Ended: (1) TTL Schmitt Trigger 1 MHz/ Channel 50% Duty Cycle
- Motor OverTemperature: (1) 0 to +5 VDC, 10 kOhm, single ended

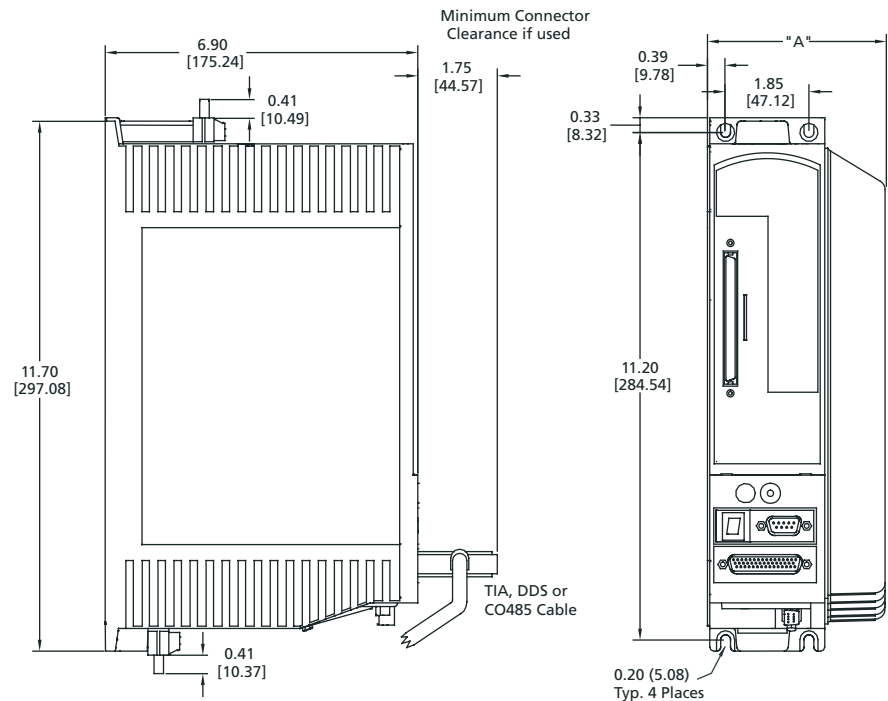

Drive Model	Dimension A
EN-204	2.93 [74.4]
EN-208	3.43 [87.1]
EN-214	3.93 [99.8]

Drive Control Outputs

- Analog: (2) +/- 10 VDC 10-bit, single ended, 20 mA
- Digital: (3) +10 to 30 VDC, 150 mA, Sourcing, Optically isolated
- Pulse Differential: RS422 and TTL compatible, 20ma/Channel, Sink or Source

I/O Supply +10 to 30 VDC

Environmental

- Rated Ambient Temperature: 32° to 104°F (0° to 40°C) for rated performance
- Maximum Ambient Temperature: 32° to 122°F (0° to 50°C) with power derating of 3.5%/1.8°F (1°C) above 104°F (40°C)
- Rated Altitude: 3280' (1000 m)
- Maximum Altitude: For altitudes >3280' (1000 m) derate output by 1%/328' (100 m) not to exceed 7560' (2000 m)
- Vibration: 10 to 2000 Hz @ 2g
- Humidity: 10 to 95% non-condensing
- Storage Temperature: -13° to 167°F (-25° to 75°C)
- Ingress Protection: IP-20

Cooling Method

- EN-204: Convection
- EN-208: Convection
- EN-214: Integral Fan

Serial Interface RS232/RS485 Modbus RTU w/32-bit extension 9600 to 19.2 kBaud Internal RS232 to RS485 Converter

Drive Weight

- EN-204: 6.4 lb (2.9 kg)
- EN-208: 7.7 lb (3.5 kg)
- EN-214: 8.9 lb (4.0 kg)

Go to
Power CD
for complete data